

**TECHNICAL MANUAL
PAINTING INSTRUCTIONS
FOR
ARMY MATERIEL**

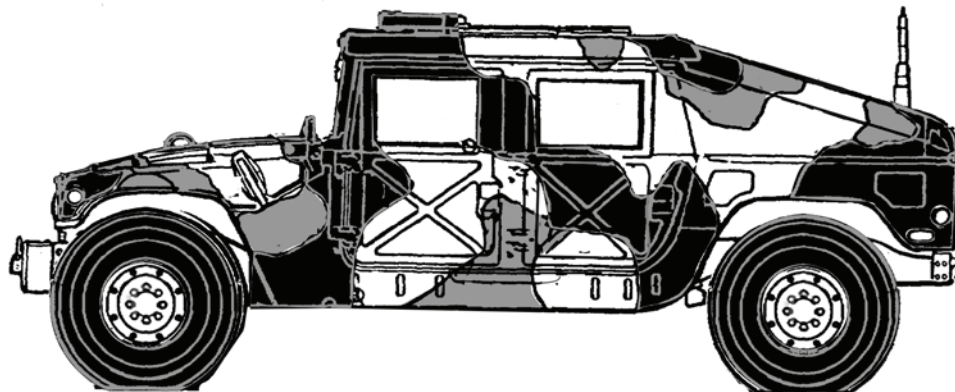

DISTRIBUTION STATEMENT A - Approved for public release; distribution is unlimited.

SUPERSEDURE NOTICE - This manual supersedes TM 43-0139, dated 27 July 1988.

**HEADQUARTERS, DEPARTMENT OF THE ARMY
JUNE 2008**

WARNING SUMMARY

FOR INFORMATION ON FIRST AID, REFER TO FM 4-25.11



SAFETY SUMMARY

The following are general safety precautions that are not related to any specific procedures and therefore do not appear elsewhere in this publication. These are recommended precautions that personnel must understand and apply during many phases of operation and maintenance.

KEEP AWAY FROM LIVE CIRCUITS

Operating personnel must at all times observe all safety regulations. Do not replace components or make adjustments inside equipment with the high voltage supply turned on. Under certain conditions, dangerous potentials may exist when the power control is in the off position, due to charges retained by capacitors. To avoid casualties always remove power, and discharge and ground circuit before touching it.

DO NOT SERVICE OR ADJUST ALONE

Under no circumstances shall any person reach into or enter an enclosure for the purpose of servicing or adjusting equipment except in the presence of someone who is capable of rendering aid.

RESUSCITATION

Personnel working with or near high voltages should be familiar with modern methods of resuscitation. Such information may be obtained from the supporting Medical Department or the Local Chapter of the Red Cross.

HAZARDOUS MATERIAL STORAGE AND HAZARDOUS WASTE DISPOSAL

Before using any paints, thinners, solvents, detergents, or other chemicals, familiarize yourself with and adhere to all manufacturers', local, state and federal standards/regulations regarding safe storage, use, and the disposal of these products. Consult the Material Safety Data Sheet (MSDS), or your local Hazardous Materials Officer or Industrial Hygienist as needed.

WARNING SUMMARY (cont)

PROPER VENTILATION

Cleaners, solvents, and paints, require adequate ventilation to be used safely. In many cases, simply working outdoors is adequate ventilation. When working in enclosed vehicles, shelters, or cabinets, ensure that there is adequate ventilation for the materials being used. If adequate ventilation can not be provided, then respirators must be worn.

PERSONAL PROTECTIVE EQUIPMENT (PPE)

Some type of Personal Protective Equipment (PPE) is usually required when performing painting procedures. PPE may include ear protection, eye protection, gloves, respirators, or other equipment. Select appropriate PPE for the job you are performing.

OXYGEN EQUIPMENT, FITTINGS, AND REGULATORS

Do not use oil-based cleaning/preservative compounds around oxygen, oxygen fittings, or oxygen regulators since fire or explosion may result.

EXPLOSION AND SPARK PROOF ELECTRICAL EQUIPMENT

Use of electrical equipment (e.g., drills and sanders) may present an explosive hazard when explosive solvent/vapors are present. Use explosive spark-proof equipment when needed, and make sure they are properly grounded.

SUMMARY OF WARNINGS

The following is a list of warnings appearing in this Technical Manual (TM).

WARNING

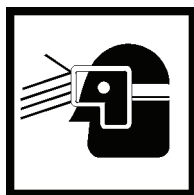

Wash down additive concentrate can cause eye irritation. Wear chemical splash proof goggles, and a face shield if needed, when mixing or when using at full strength. Failure to do so may cause death or injury to personnel. If material contacts eyes, flush with plenty of fresh water for 15 minutes and get immediate medical attention.

WARNING SUMMARY (cont)

WARNING

Keep cleaners out of eyes. Use splash-proof goggles to prevent material from being splashed into eyes when being mixed and/or applied. In addition to goggles, a plastic face shield may also be used. The face shield is not to be used in lieu of goggles. If material contacts eyes, flush with plenty of water and follow instructions on MSDS.

WARNING

Paint thinners can cause eye irritation. Wear chemical splash proof goggles, and a face shield if needed, when mixing or when using at full strength. Failure to do so may cause death or injury to personnel. If material contacts eyes, flush with plenty of fresh water for 15 minutes and get immediate medical attention.

WARNING



Solvents are flammable and toxic. Use only in well ventilated spaces. If ventilation cannot be provided and work would result in breathing solvent vapors, wear air-purifying respirator equipped with organic vapor cartridge. Do not use near open flames or sources of sparks. Do not smoke in the area where solvents are being used. Do not allow prolonged contact of solvent with bare skin. Failure to do so may result in death or injury to personnel.

WARNING



The catalyst used in this sealer contains a lead compound. Avoid contact with skin. Wash hands after use. Failure to do so may result in death or injury to personnel.

WARNING SUMMARY (cont)

WARNING



Ensure that any electrical or electronic equipment is de-energized and properly tagged-out in accordance with local procedures before working on it. Failure to do so may result in death or injury to personnel.

WARNING

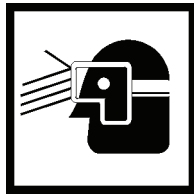

Use of hand tools can cause hand or eye injury. Some of these tools can create flying debris. Wear protective gloves and impact resistant eye protection. Failure to do so may result in death or injury to personnel.

WARNING

When using compressed air to blow off a surface, beware of flying debris. Wear impact resistant eye protection. Do not use compressed air to blow dust or debris off of clothes. Failure to do so may result in death or injury to personnel.

WARNING SUMMARY (cont)

WARNING



Power tools can cause hand or eye injury and may produce high noise levels and airborne dust. These tools can create flying debris – use impact resistant eye protection. Follow all safety precautions for the power tool used. Do not defeat or disable any safety mechanisms. Failure to do so may result in death or injury to personnel.

WARNING



Protect eyes from splashes when mixing and applying paint. Avoid inhalation of paint fumes. Paint only in areas of adequate ventilation. Wear a respirator when mixing or applying paint if adequate ventilation cannot be obtained. Failure to do so may result in death or injury to personnel.

Prior to beginning any painting operation, Preventive Medicine/Industrial Hygiene personnel must be contacted. Painting materials can cause serious health problems if used improperly or without adequate respiratory protection. Failure to do so may result in death or injury to personnel.

WARNING SUMMARY (cont)

WARNING



Avoid breathing vapors from sealants. Do not use sealants in poorly ventilated areas. Doing so may result in death or injury to personnel.

WARNING



Post "NO SMOKING" signs in and within a 50 foot radius of paint spraying and storage areas. Failure to do so may result in death or injury to personnel.

WARNING

Observe fire regulations when using paints, lacquers, primers, removers and thinners; many are highly flammable. Keep away from heat, flames and sparks. Failure to do so may result in death or injury to personnel.

WARNING

Dried spray-paint dust can pose an extreme fire hazard. Remove and dispose of this dust daily in accordance with AR 420-1. The danger of fire can be materially reduced by the use of a water-wash or waterfall type of spray booth. Failure to do so may result in death or injury to personnel.

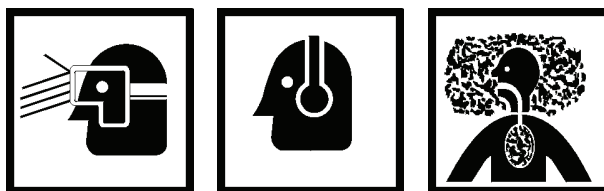
WARNING SUMMARY (cont)**WARNING**

Eye and hearing protection must be worn at all times when using power tools for grinding, cutting, sawing, and drilling. Personnel grinding or sanding on painted equipment should use high efficiency air-purifying respirators. Failure to do so may result in injury to personnel.

WARNING

CARC topcoat paint contains isocyanides (ICN), which can trigger an allergic reaction in some people (lasting a few days to a few months) producing asthmatic like symptoms such as coughing, wheezing, tightness in the chest, shortness of breath, including reddening of the skin and eyes, and itching. If you are or become sensitized to CARC paint never use or apply CARC paint even if the above symptoms are minor. Observe the following precautions to ensure the safety of personnel when CARC paint is applied:

- For spray/brush/roller painting in confined spaces, an air-line respirator is required, unless an air sampling shows exposure to be below standards. If air sampling is below standards, either chemical cartridge or air-line respirators are required.
- Spot painters applying CARC paint by brush or roller must wear clothing and gloves affording full coverage. Personnel using touch-up spray kits should wear an air-line respirator and protective clothing.

WARNING SUMMARY (cont)

- Do not use alcohol or amine-based solvents to thin or remove CARC paints. Use of solvents with CARC paints can produce chemical reactions resulting in nausea, disease, burns or severe injury to personnel.
- Do not use paint solvents to remove paint/coating from skin.
- Mix paint/coating in a well-ventilated mixing room or spraying area away from open flames. Personnel mixing paint/coating should wear eye protection.
- Use paint/coating with adequate ventilation.
- Personnel grinding or sanding on painted equipment should use high efficiency air-purifying respirators.

WARNING

Never weld or use a cutting torch on CARC or WD CARC-painted material. Welding or cutting painted surfaces release toxic gases, vapors and metal fumes.

TM 43-0139

LIST OF EFFECTIVE PAGES/WORK PACKAGES

Note: This manual supersedes TM 43-0139 dated 27 July 1988. Zero in the "Change No." column indicates an original page or work package.

Dates of issue for original pages/work packages are:

Original 30 JUNE 2008

TOTAL NUMBER OF PAGES FOR FRONT AND REAR MATTER IS 22 AND TOTAL NUMBER OF WORK PACKAGES IS 21 CONSISTING OF THE FOLLOWING:

Page/WP No.	Change No.	Page/WP No.	Change No.	Page/WP No.	Change No.
Front Cover	0	WP 0008 (6 pgs)	0	WP 0019 (4 pgs)	0
blank	0	WP 0009 (12 pgs)	0	Chp 7 Title Page	0
Warning Summary (8 pgs)	0	WP 0010 (10 pgs)	0	blank	0
i - ii	0	Chp 4 Title Page	0	WP 0020 (4 pgs)	0
Chp 1 Title Page	0	blank	0	WP 0021 (10 pgs)	0
blank	0	WP 0011 (10 pgs)	0	GLOSSARY-1 – GLOSSARY-4	0
WP 0001 (4 pgs)	0	WP 0012 (10 pgs)	0	INDEX-1 – INDEX-2	0
WP 0002 (6 pgs)	0	Chp 5 Title Page	0	DA Form 2028 Sample (2 pgs)	0
Chp 2 Title Page	0	blank	0	DA Form 2028 (4 pgs)	0
blank	0	WP 0013 (30 pgs)	0	Authentication Page	0
WP 0003 (4 pgs)	0	WP 0014 (10 pgs)	0	Blank	0
WP 0004 (2 pgs)	0	WP 0015 (8 pgs)	0	Metric Page	0
WP 0005 (2 pgs)	0	Chp 6 Title Page	0	Back Cover/PIN	0
WP 0006 (2 pgs)	0	blank	0		
Chp 3 Title Page	0	WP 0016 (8 pgs)	0		
blank	0	WP 0017 (2 pgs)	0		
WP 0007 (16 pgs)	0	WP 0018 (4 pgs)	0		

A/(B Blank)

**TECHNICAL MANUAL
PAINTING INSTRUCTIONS
FOR
ARMY MATERIAL**

REPORTING ERRORS AND RECOMMENDING IMPROVEMENTS

You can help improve this publication. If you find any errors, or if you would like to recommend any improvements to the procedures in this publication, please let us know. The preferred method is to submit your DA Form 2028 (Recommended Changes to Publications and Blank Forms) through the Internet, on the Army Electronic Product Support (AEPS) website. The Internet address is <https://aeprs.ria.army.mil>. The DA Form 2028 is located under the Public Applications section in the AEPS Public Home Page. Fill out the form and click on SUBMIT. Using this form on the AEPS will enable us to respond quicker to your comments and better manage the DA Form 2028 program. You may also mail, e-mail, or fax your comments or DA Form 2028 directly to the U.S. Army TACOM Life Cycle Management Command. The postal mail address is U.S. Army TACOM Life Cycle Management Command, ATTN: AMSTA-LC-LMPP / TECH PUBS, 1 Rock Island Arsenal, Rock Island, IL 61299-7630. The e-mail address is tacomlcmc.daform2028@us.army.mil. The fax number is DSN 793-0726 or Commercial (309) 782-0726.

SUPERSEDURE NOTICE – This manual supersedes TM 43-0139 dated 27 July 1988.
DISTRIBUTION STATEMENT A: Approved for public release; distribution is unlimited.

TABLE OF CONTENTS

	<u>Page Number</u>
CHAPTER 1. INTRODUCTION	
WP 0001 00 General Information	0001 00-1
WP 0002 00 Safety Summary	0002 00-1
CHAPTER 2. UNDERCOATS, FINISH MATERIALS, AND RELATED PRODUCTS	
WP 0003 00 Fillers	0003 00-1
WP 0004 00 Primers	0004 00-1
WP 0005 00 Cleaners	0005 00-1
WP 0006 00 Thinners.....	0006 00-1

TABLE OF CONTENTS (continued)

CHAPTER 3. FINISH SYSTEMS

WP 0007 00 Spot Painting..... 0007 00-1
 WP 0008 00 Cleaning and Treatment of Surfaces 0008 00-1
 WP 0009 00 Painting 0009 00-1
 WP 0010 00 Specific Finish Systems 0010 00-1

CHAPTER 4. CAMOUFLAGING PROCEDURES

WP 0011 00 Camouflaging Pattern Painting 0011 00-1
 WP 0012 00 Inspection Procedures 0012 00-1

CHAPTER 5. APPLICATION TECHNIQUES AND EQUIPMENT

WP 0013 00 Spray Guns and Pressure Cans 0013 00-1
 WP 0014 00 Brush or Roller Application 0014 00-1
 WP 0015 00 Paint Failures 0015 00-1

CHAPTER 6. MARKING PROCEDURES

WP 0016 00 Lettering and Sign Painting 0016 00-1
 WP 0017 00 Stencil and Paint Marking 0017 00-1
 WP 0018 00 Pressure Sensitive Adhesive Vinyl Markers (Decals) 0018 00-1
 WP 0019 00 Pouncing 0019 00-1

CHAPTER 7. SUPPORT DATA

WP 0020 00 References..... 0020 00-1
 WP 0021 00 National Stock Number (NSN) Tables 0021 00-1

GLOSSARY GLOSARRY-1

INDEX INDEX-1

CHAPTER 1
INTRODUCTION
FOR
PAINTING INSTRUCTIONS FOR
ARMY MATERIEL

GENERAL INFORMATION

PURPOSE

This Technical Manual (TM) is published to provide information and guidance to personnel charged with painting and marking equipment for which the U.S. Army has responsibility. It contains instructions for treating surfaces to remove corrosion, and procedures for preventing corrosion by applying protective coatings. Although many paint systems are covered, special emphasis is placed on the Chemical Agent Resistant Coatings (CARC), system because they are particularly effective in resisting corrosion and chemical penetration, and are also decontaminated more easily than are other coatings.

SCOPE

This TM discusses materials associated with painting operations, procedures for marking, and camouflaging equipment, and methods of applying paint.

This manual is applicable to equipment under U.S. Army jurisdiction, whether assigned to active service or in wet or dry storage. Additional information for painting watercraft is contained in TB 43-0144, Painting of Watercraft. For additional information for painting Military vehicles, construction equipment and material handling equipment, refer to TB 43-0209, and MIL-HDBK-1473A, Color and Marking of Army Materiel. For detailed corrosion correction and prevention techniques, refer to TB 43-0213.

POLICY

There are Safety, Health and Environmental requirements associated with all aspects of painting operations. These are outlined in Work Package (WP) 0002 00, Safety Summary of this chapter. Personnel must keep these requirements in mind before, during and after undertaking any painting activity. Any questions should be directed to local preventive medicine/industrial hygiene personnel.

Equipment with applied coatings providing satisfactory protection will not be altered solely for conformity to requirements herein. Complete repainting should be done only when existing finish has deteriorated to the extent that it no longer protects the underlying surface or when higher authority mandates. Camouflage patterns may be painted on items coated with Green 383 (34094) anytime after pattern design development, at the Commanding Officer's discretion.

Chemical Agent Resistant Coatings (CARC) are required on all combat, combat support, and combat service support equipment. Current alkyd and lacquer paints must be removed after chemical agent exposure as paints absorb liquid agents and release agents over time, causing a contact hazard. Since CARC does not absorb chemical agents it does not create long term contact hazards.

Only Field Level Maintenance and Sustainment Level Maintenance personnel with equipment and paint booths meeting Occupational Safety & Health Administration (OSHA) standards are authorized complete painting and repainting with any topcoat or primer. If such equipment/booths are not available, only touch-up efforts are authorized.

POLICY (continued)

The style, size and exact location of markings prescribed in this manual are specified in applicable technical bulletins in the 43 and 746 series and other DA technical publications. Markings may be applied in the form of adhesive backed markers of the prescribed color, or may be painted on when markers are unavailable or application must be made on canvas or other porous surfaces.

Special markings for vehicles in administrative use are included in AR 58-1, Management, Acquisition, and use of Motor Vehicles.

Under tactical conditions, when requirements for concealment outweigh those for recognition, all conspicuous markings may be obscured or removed by the authority and at discretion of major organization commander present. Protective markings may be obscured only at direction of responsible major tactical commander.

Major end items and major components with exposed surfaces painted with Chemical Agent Resistant Coatings (CARC) will have the word "CARC" stenciled on them in close proximity to the data plate. Refer to WP 0011 00, Camouflage Pattern Painting of this Technical Manual (TM).

Markings on exterior of tactical equipment will be applied using CARC in accordance with WP 0017 00, Stencil and Paint Marking, of this TM.

Safety markings, including hazard warning and caution information, for non-tactical equipment, tactical not subject to Army camouflage policy, and equipment at fixed facilities will comply with provision of AR 385-30, Safety Color Code Markings and Signs. Materiel painted in camouflage requiring hazard warning and caution information will have this information applied in accordance with WP 0011 00, Camouflage Pattern Painting of this TM.

Additional marking policy is contained in AR 750-1, Army Materiel Maintenance Policy.

PURPOSE OF PAINTING

The primary function of painting is to protect metals, wood, and other material against corrosion and decay.

Paint should not be applied to unseasoned wood, since paint retards the seasoning process and fails to form a proper coating under such conditions.

Certain paints adhere to a given surface better than others and therefore furnish a better protective coating. The first or base coat should penetrate into minute depressions or pits in material and should adhere well enough to form a good bond for any additional coats.

Success of painting depends on selection of a suitable paint, and also upon care used in preparing the surface, which should be thoroughly cleaned, dry, and smooth. Other factors include method of application, and weather conditions.

Camouflage of Army materiel is a function of paint. WP 0011 00, Camouflage Pattern Painting, of this TM, discusses reasons for camouflaging.

PURPOSE OF PAINTING (continued)

White and light-tinted paints are frequently used on interior surfaces to increase visibility in spaces with limited access to outside light. In this respect, paint can serve to increase visibility with existing natural or artificial light, or it can serve to reduce amount of natural or artificial light required in a given interior space.

Chemical Agent Resistant Coatings (CARC) are used to protect combat, combat support, and combat service support equipment from chemical agent penetration. These coatings can be decontaminated relatively easily.

Paint can be used to apply identification marks to equipment. Chapter 6, Marking Procedures, contains instructions for marking Army materiel. Markings on camouflaged equipment will be in accordance with WP 0011 00, Camouflage Pattern Painting of this Technical Manual (TM).

END OF WORK PACKAGE

SAFETY SUMMARY

SCOPE

This Work Package (WP) outlines Safety, Health and Environmental requirements applicable to all painting operations. Safety and Health requirements are the same, regardless of paint system used, except where specifically identified. If there is ever uncertainty as to what is required, contact local Preventive Medicine/Industrial Hygiene personnel.

Vapors

Thinners used with paints and primers may have harmful effects. Continued breathing of vapors during and after painting operations should be avoided. Toxic vapors may persist, in some cases, for many days indoors after painting operations. Every effort must be made to ensure proper ventilation of paint area to rid area of toxic vapors as quickly as possible. All personnel must be made aware that toxic vapors may be present. Avoid inhaling toxic vapors.

Contact With Paint Materials

Avoid skin contact with paints, primers, removers and thinners, particularly if there are cuts or open wounds on hands. Unwashed hands may convey toxic material to food. Many paints and primers contain lead, chromium, or other toxic materials which may enter the body when paint-contaminated food is eaten. Many thinners are also toxic, and can enter the human body through skin or by eating contaminated food. Personal Protective Equipment (PPE) should be worn to prevent skin contact.

Fire

The mist that comes from a spray gun is highly flammable. A spark will cause it to flash. Smoking is prohibited in paint shops. Open cans containing paint removers, thinners, paints, and primers are a fire hazard. Empty drums or other containers in which paints, primers and thinners have been shipped are potential hazards since they often contain enough vaporized material of a flammable nature to cause explosions. Accumulated overspray in booths and in cracks and corners of paint shop is particularly dangerous for it easily flares up. Oil or solvent-soaked cloths, if not properly contained and promptly disposed of in accordance with AR-420-1, Army Facilities Management, may cause fire by spontaneous combustion. Fires which occur in spray booths result from six principal causes: broken electric lamps and other electrical defects; cleaning interior of booths, fans, and motors with flammable solvents; accumulations of deposits in booths, tubes, and vent pipes; defective fans and motors used for ventilating booths; poorly designed vent tubes; or static electricity.

Safe Air

If it is at all practical, painting of material should be accomplished in a properly designed and operated paint booth. Adequate forced draft ventilation for indoor touchup work should be provided to carry off vapors. Respirators should be worn during all spray-painting operations.

GENERAL (continued)**Safe Practices**

Preparations containing benzene should not be used for spraying. Only electrical equipment/wiring conforming to the National Electrical Code NFPA70 will be used where spray-painting is being accomplished. Paints should be stored in a steel cabinet, meeting Occupational Safety & Health Administration (OSHA) requirements. Once opened, cans containing paint removers, thinners, paints, and paint materials should be covered tightly before being stored or put away overnight. Do not apply heat or flame to drums, cans, or other containers that have contained flammable materials. Observe safe operating procedures at all times, particularly when handling cleaning materials.

MATERIAL SAFETY DATA SHEETS (MSDS)

MSDS are prepared by Manufacturer and should accompany each single shipment or batch of paint, primer or thinner. It is mandatory that personnel working with these substances read this information. Because of variations involved, MSDS must be reviewed for each shipment procured on a single purchase order. MSDS must be filed in a location readily accessible to workers exposed to substances. MSDS also assist management by directing attention to need for specific control engineering, work practices and protective measures to ensure safe handling and use of material. Along with product's ingredients and specific protection information, MSDS contain the following data:

Reactivity Data

This informs paint user about stability, hazardous decomposition, or polymerization properties of the coating.

Spill And Disposal Procedures

This informs paint user steps to be taken for proper spill or disposal methods.

Fire And Explosion Hazard Data

This informs paint user about flash point of product, special fire fighting procedures, and extinguishing media.

Health Hazards

Personnel should be familiar with emergency and first aid procedures as outlined in product's MSDS. This includes medical procedures to be followed if product is inhaled, or if product has come in contact with skin or eyes of an individual.

CONTROL MEASURES

Personal Protective Equipment (PPE) used in conjunction with respiratory protection equipment during spray-painting includes cloth coveralls, eye protection, and head coverings. Cloth gloves are suitable unless cello solve acetate (2-ethoxyethyl acetate) is present in paint, solvent, or primer. When this solvent is present, silicon rubber gloves are recommended. Spot painters applying paint by brush or roller must wear work clothing and gloves affording full skin coverage. Persons who clean mixing and painting accessories should wear full PPE to preclude solvent absorption and defatting of hands caused by thinner.

Personal Protection

If a solvent with a skin notation is being used, then impervious gloves must be used. Barrier creams are useful in preventing paint from adhering to skin and in combating "dryness" associated with defatting action of most solvents; however, their usefulness in preventing absorption of solvent through skin is not documented. Solvents must never be used to remove paint/coating from skin.

Work clothing should be provided. After completing painting or sanding operations, hygienic showers should be taken prior to changing into street clothing.

Respiratory Protection

WARNING



Prior to beginning any painting operation, Preventive Medicine/Industrial Hygiene personnel must be contacted. Painting materials can cause serious health problems if used improperly or without adequate respiratory protection. Failure to do so may result in death or injury to personnel.

Before beginning painting operations, contact local Preventive Medicine/Industrial Hygiene personnel, who will determine minimum respiratory protection requirements in accordance with TB MED 514, Guidelines For Controlling Health Hazards In Printing Operations depending on method of application and facilities available, some sort of respirator, will probably be required.

Levels of exposure to contaminants will be documented by Preventive Medicine/Industrial Hygiene personnel. Additional monitoring is required whenever there has been any change in operation which could result in new or additional exposures.

Ventilation

The use of respiratory protection equipment does NOT waive the requirement for engineering control measures. The ventilation design specifications for spray paint booths are in TB MED 514.

Preferred Coatings

Whenever available, lead-and chromate-free coatings should be used.

Warning Labels

Warning labels are required on products which contain materials hazardous to your health. Read these warnings.

MEDICAL SURVEILLANCE

Medical surveillance to detect adverse health effects will be determined by the Installation Medical Authority (IMA) based on the specific constituents of the coating. In general, medical surveillance is required for anyone who works more than thirty (30) days per year in either a paint spraying operation or in a brush or roller application when respiratory protection is required. Personnel involved in painting at Field Level Maintenance, and Sustainment Level Maintenance will normally require surveillance. Vehicle/equipment operators usually do not perform enough brush touch-up painting to warrant medical surveillance.

DISPOSAL**General**

Unusable paint mixtures, paint components, primers, thinners and other materials may be considered hazardous waste and require disposal in accordance with Federal, State, Department of Defense (DOD), and Department of the Army (DA) hazardous waste regulations. This may apply to dried paint/primer waste as well. Consult local Environmental personnel for proper disposal guidance.

Method of Disposal

The method used to dispose of this waste stream depends on types of paint used. When paints contain no hazardous heavy metals, liquid portion of waste stream may be able to be discharged into sanitary sewers and sludge disposed of in a sanitary landfill. The Environmental Coordinator should be contacted to ensure state and local ordinances are not violated.

If a sanitary sewer serving a paint processing operation discharges to a government-operated Sewage Treatment Plant (STP), notify STP operator of approximate additional loadings of total organic carbon, biochemical oxygen demand, and total processing operation prior to discharge.

METHOD OF DISPOSAL (continued)

If a sanitary sewer serving a paint processing operation discharges to privately owned treatment works, pretreatment of wastewaters may be required by local regulatory authority. The installation Environmental Coordinator should determine such cases with public environmental regulators having primacy over government installations.

OTHER PUBLICATIONS

Additional safety and environmental information is contained in Work Package WP 0020 00, References, of this Technical Manual (TM).

END OF WORK PACKAGE

CHAPTER 2
UNDERCOATS, FINISH MATERIALS, AND RELATED PRODUCTS
FOR
PAINTING INSTRUCTIONS FOR
ARMY MATERIEL

FILLERS

GENERAL

This chapter is intended to serve as a general guide to selection of suitable materials, procedures, and systems for painting and otherwise finishing metal and wood surfaces. If correct finish system is used and properly applied, it will keep maintenance to a minimum. Otherwise, moisture or other substances will penetrate coating and cause metal to corrode or wood to rot. Usually a finish coat alone will not provide sufficient protection. For example, lusterless olive-drab enamel, which is somewhat porous, offers relatively little protection; its main function is camouflage. The required protection is provided mainly by primers that, for metal, contain corrosion inhibiting pigments, and for wood, have high moisture resistant qualities.

FILLERS

Fillers, like primers and sealers, are undercoats used to prepare metal or wood surfaces for subsequent and final coats of paint. They are heavy-bodied pigment materials, and except for graduation fillers, are applied with a putty knife, spatula, or other similar tool. They are always used in conjunction with finish coats.

WARNING



Avoid breathing vapors from sealants. Do not use sealants in poorly ventilated areas. Doing so may result in death or injury to personnel.

SEALING COMPOUND, ADHESIVE: CURING (POLYSULFIDE BASE) (A-A-59293)**Salient Characteristics**

This sealing compound is a two-part material consisting of a black (polysulfide) base compound and an accelerator to be mixed according to instructions. This compound and accelerator are contained in a two-compartment container. After curing, compound forms a rubber like material and provides satisfactory adhesion.

Use

This compound is used for sealing and plugging exposed holes in optical instruments or fire control instruments, such as holes for setscrews, adjusting screws, and slugs that are accessible from outside of instrument.

SEALING COMPOUND, ADHESIVE: CURING (POLYSULFIDE BASE) (A-A-59293) (continued)

WARNING



The catalyst used in this sealer contains a lead compound. Avoid contact with skin. Wash hands after use. Failure to do so may result in death or injury to personnel.

Curing

The compound cures in 72 to 96 hours at approximately 80°F (27°C).

FINISH SYSTEMS

Protective coatings are applied to metal and wood surfaces to protect them from destructive action of moisture and other injurious agents. In addition, colored coatings improve appearance of surfaces to which they are applied and serve to denote the Military organization to which item being painted belongs. Coatings must also resist weathering, cleaning, fumes, oil, the action of fungi, and other causes that impair their protective qualities.

Because no single finish material can fulfill all requirements mentioned above, finishes, as applied to both metal and wood, are usually composed of two or more materials, each of which serve a definite purpose in the combination coating known as a "finish system". Detailed information on finish systems may be found in Chapter 3, Finish Systems, of this Technical Manual (TM), and in MIL-STD-171, Finishing of Metal and Wood Surfaces; and MIL-DTL-53072, Chemical Agent Resistant Coating (CARC) System.

FINISH SYSTEM MATERIALS

Fillers

Fillers are heavy-body materials, usually in paste form, that are used to fill depressions and holes and provide a smooth surface after sanding.

Primers

Primers are used on metals to provide a corrosion-resistant coating to which subsequent finish coat will firmly adhere.

Sealers

Sealers are used to fill or seal pores of wood and prevent contamination of a finish coat by "bleeding" of an underlying stain or colored filling material. Certain sealers also contain fungicides.

Topcoat or Finish Coat

This is the final coat in a finish system. It may be enamel, or CARC paint, depending on service requirements desired.

END OF WORK PACKAGE

PRIMERS

GENERAL

This Work Package (WP) describes application of various primers used for Chemical Agent Resistant Coating (CARC) and non CARC paint systems. Primers are applied to metal to provide an initial coating to which a second coating (i.e. a topcoat) will firmly adhere. The pigment composition of primers for ferrous-base metals usually consists of iron oxide, titanium dioxide, zinc, zinc dust, zinc oxide and zinc phosphate, inert extenders (TALC, CLAYS) or a mixture of these.

WARNING

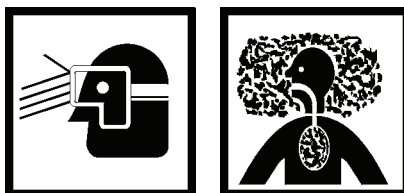

Protect eyes from splashes when mixing and applying primer paint. Avoid inhalation of primer paint fumes. Paint only in areas of adequate ventilation. Wear a respirator when mixing or applying primer paint if adequate ventilation cannot be obtained. Failure to do so may result in death or injury to personnel.

PRIMER, EPOXY COATING, CORROSION INHIBITING, LEAD AND CHROMATE FREE (MIL-DTL-0053022)**Characteristics**

This is a two part, flash drying corrosion inhibiting, lead and chromate free epoxy primer for use on ferrous and non-ferrous metals which must meet air pollution requirements.

Use

It may be used to replace MIL-PRF-23377 where exposure to lead and chromate pigments is not permitted. It is a primer for use with CARC paints.

PRIMER COATING, EPOXY, WATER REDUCIBLE, LEAD AND CHROMATE FREE (MIL-DTL-0053030)**Characteristics**

This primer is a water reducible, air drying, corrosion inhibiting, and two part epoxy system. It is lead and chromate free.

Use

It is intended for use on pretreated ferrous and non-ferrous substrates, and is compatible with polyurethane topcoats. It contains no more than 2.81 pounds per gallon (340 grams per liter) of Volatile Organic Compounds (VOC) as applied. It is a primer for use with CARC paints.

PRIMER COATING, EPOXY, WATER REDUCIBLE, LEAD AND CHROMATE FREE (MIL-DTL-0053030) (continued)

Application

Thoroughly stir Component A by hand until uniform. Mix Component B with Component A in volume specified by Manufacturer. An induction of 30 minutes is necessary after mixing. Epoxy primers have a pot life of 15 hours.

Drying Time

The sprayed primer will be set to touch within 45 minutes and dry hard within two hours.

Thinner

Reduce the admixed primer with water. When spraying, this primer should have a viscosity of 20 seconds in a viscometer cup.

END OF WORK PACKAGE

CLEANERS

GENERAL

This Work Package (WP) describes types of cleaners used for painted or unpainted metal parts.

WARNING

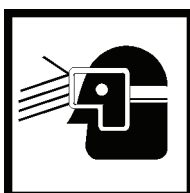

Keep cleaners out of eyes. Use splash-proof goggles to prevent material from being splashed into eyes when being mixed and/or applied. In addition to goggles, a plastic face shield may also be used. The face shield is not to be used in lieu of goggles. If material contacts eyes, flush with plenty of water and follow instructions on MSDS.

WARNING



Solvents are flammable and toxic. Use only in well ventilated spaces. If ventilation cannot be provided and work would result in breathing solvent vapors, wear air-purifying respirator equipped with organic vapor cartridge. Do not use near open flames or sources of sparks. Do not smoke in the area where solvents are being used. Do not allow prolonged contact of solvent with bare skin. Failure to do so may result in death or injury to personnel.

Degreasing Solvent (MIL-PRF-680)

These solvents are hydrocarbon-based solvents and are used as degreasers and cleaners for painted or unpainted metal parts. However, the compatibility between existing paints and solvents should be verified prior to use. It is recommended that solvents should be used with an appropriate recirculated parts washer. No other commercial specification is available to cover these military applications.

Type I (Stoddard solvent)

Is intended for use where a low odor solvent fast drying characteristics is desired. This solvent is currently defined as a flammable material due to its low flash point. It is recommended that the alternative solvents for Type I are Types II, III and IV. When Type I solvent is used indoors, ventilation should be sufficient to prevent the accumulation of vapors above allowable limits.

Degreasing Solvent (MIL-PRF-680) (continued)**Type II (low odor with high flash point solvent)**

Is intended for use where solvent with a higher flash point is desired. It is recommended over Type I for safety and regulatory reasons. When Type II solvent is used indoors, ventilation should be sufficient to prevent the accumulation of vapors above allowable exposure limits.

Type III (low odor with very high flash point solvent)

Is intended to be where confined atmospheric conditions require a cleaner that conforms to the Federal Government's directives for reduced hazardous materials.

Type IV (citrus odor with high flash point)

Is intended for use where a solvent with a high flash point and strong solvency is desired. This solvent is formulated with petroleum based hydrocarbon solvents and d-limonene additive. When Type IV solvent is used indoors, ventilation should be sufficient to prevent the accumulation of vapors above allowable exposure limits.

Acetone (ASTM D329)

Acetone is a colorless, mobile, flammable liquid. It is the simplest example of the ketones. Acetone is miscible with water, ethanol, ether, etc. and itself serves as an important solvent. The most familiar household use of acetone is as the active ingredient in nail polish remover. Acetone is also used to make plastic, fibers, drugs, and other chemicals. In addition to being manufactured as a chemical, acetone is also found naturally in the environment, including in small amounts in the human body.

END OF WORK PACKAGE

THINNERS

GENERAL

Thinners make paint workable by adjusting the paint or coating consistency for easy application. This Work Package (WP) describes types of thinners used.

WARNING



Paint thinners can cause eye irritation. Wear chemical splash proof goggles, and a face shield if needed, when mixing or when using at full strength. Failure to do so may cause death or injury to personnel. If material contacts eyes, flush with plenty of fresh water for 15 minutes and get immediate medical attention.

WARNING



CARC topcoat paint contains isocyanates (ICN), which can trigger an allergic reaction in some people (lasting a few days to a few months) producing asthmatic like symptoms such as coughing, wheezing, tightness in the chest, shortness of breath, including reddening of the skin and eyes, and itching. If you are or become sensitized to CARC paint never use or apply CARC paint even if the above symptoms are minor. Observe the following precautions to ensure the safety of personnel when CARC paint is applied:

- Do not use alcohol or amine-based solvents to thin or remove CARC paints. Use of solvents with CARC paints can produce chemical reactions resulting in nausea, disease, burns or severe injury to personnel.

- Do not use paint solvents to remove paint/coating from skin.
- Mix paint/coating in a well-ventilated mixing room or spraying area away from open flames. Personnel mixing paint/coating should wear eye protection.

THINNER, AIRCRAFT COATING MIL-T-81772

This thinner is used with Chemical Agent Resistant Coating (CARC) topcoats and primers. Type I is used with Coating, Aliphatic Polyurethane, Single Component, Chemical Agent Resistant, MIL-DTL-53039 and those CARC epoxy enamels and primers using MIL-T-81772, Type II, if Type II is not available. Type II is used with Coating, Epoxy, High-Solids, MIL-PRF-22750, or Primer, Epoxy Coating, Corrosion Inhibiting, Lead and Chromate Free, MIL-DTL-0053022. Other thinners used must be in accordance with Manufacturer's recommendations or instructions.

END OF WORK PACKAGE

CHAPTER 3
FINISH SYSTEMS
FOR
PAINTING INSTRUCTIONS FOR
ARMY MATERIEL

SPOT PAINTING

INTRODUCTION

An epoxy primer is applied over a cleaned and pretreated metal surface followed by a urethane top coat in accordance with MIL-DTL-53072, Chemical Agent Resistant Coating (CARC) System Application Procedures and Quality Control Inspection. Strict adherence to the above system is required for all coatings to bond properly to each other and to surface being painted. For exterior surfaces a primer, MIL-DTL-0053030, Primer Coating, Epoxy, Water Reducible, Lead and Chromate Free, and topcoat MIL-DTL-64159, Coating, Water Dispersible Aliphatic Polyurethane, Chemical Agent Resistant, are preferred for ease of use, clean up, and personal exposure because they contain less organic solvents. The interior for some classes of vehicles are painted with an epoxy interior coat only in accordance with MIL-PRF-22750, Coating, Epoxy, High-Solids. No other top coat is required in this circumstance.

SCOPE

This Work Package (WP) describes application of Chemical Agent Resistant Coating (CARC) system for spot painting, after surface preparation. When touching up damaged areas, procedures should be as similar to original method of finishing as possible; a clean surface is imperative. If old finish is in good condition, clean surface with a compatible cleaning solvent and apply topcoat. Where general disintegration of surface is evident, or under surface is corroded, coating must be stripped clean from the part. Corrosion must be removed or neutralized by mechanical or chemical treatment, or both, and surface metal must be penetrated, primed, and then top coated.

INDUCTION TIME

This is waiting time, or standing time, required for paint components (hardener and resin) to react prior to application. The induction time begins after mixing, and is temperature dependent. Longer induction times are needed under cool conditions.

POT LIFE

This is amount of time that paint can be used following mixing before paint begins to harden or thicken in can and becomes unusable. The pot life is temperature dependent; high temperatures reduce pot life, cool temperatures increase pot life. Each paint is shipped with data sheets containing specific details on mixing, application, pot life, and induction time. These details may vary with each type of paint, so procedures given here are general in nature. In general, painting should be performed when temperature is between 40 – 95°F (4 – 35°C), and when relative humidity is 85 % or below, or paint may not dry or perform properly.

APPLICATION METHODS**Brush Application**

The following are some general guidelines for paint application using brushes.

- a. Round or oval brushes are generally best for rivets, bolts, irregular surfaces, and rough or pitted metal. Wide, flat brushes are better for large, flat areas, but should not have a width over five (5) inches (127 cm).
- b. Brush so that a smooth, uniformly thick coat is obtained.
- c. Work paint into all pits and corners where possible.
- d. Brush out all runs and sags, leaving a minimum of brush marks.
- e. Surfaces not accessible to brushes should be painted using daubers or mitts.

Roller Application

The following are some good practices that should be considered when painting with a roller.

- a. Roller application may be used on flat or slightly curved surfaces.
- b. Select rollers based on paint Manufacturer's recommendations, if known.
- c. The use of rollers on irregular surfaces such as rivets, bolts, crevices, welds, corners, or edges is not recommended.
- d. Once an area has been painted, do not go back to touch up until paint has dried completely.

SURFACE PREPARATION

Surface preparation is important. If you skip it, or skimp on it, the paint won't stick to the surface. You can apply WD CARC over CARC, but the old topcoat must be clean, sound, and tightly bonded to the surface. Inspect the surface to be spot painted and follow the following steps:

SURFACE PREPARATION (continued)

Sanding

WARNING



Eye and hearing protection must be worn at all times when using power tools for grinding, cutting, sawing, and drilling. Personnel grinding or sanding on painted equipment should use high efficiency air-purifying respirators. Failure to do so may result in injury to personnel.

If topcoat is merely scratched, lightly scuff sand blemished area. Damage that exposes bare metal often involves rust. You must remove all traces of rust by sanding or with an orbital grinder. The surface immediately surrounding exposed metal should then be sanded, using a feathering-in technique. Refer to Figure 7-1.

In other words, thickness of the film should be smoothly tapered starting from the center and going from bare metal, to primer, to topcoat. Clean up any dust or paint particles with a wet/ dry HEPA vacuum, wet wipes, or sweep up using a sweeping compound to suppress dust.

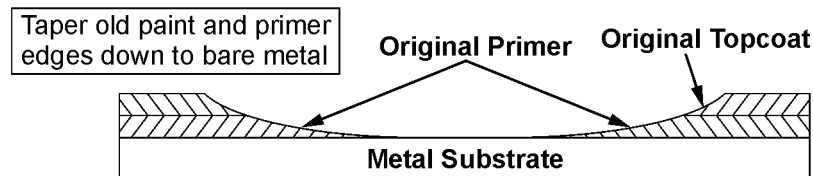

Figure 8-1

Figure 7-1. Surface Preparation

Cleaning

Wash surface thoroughly with a solution of liquid detergent, MIL-D-16791, and water. You must remove all loose sanding debris, grease, oil (including fingerprints), and fuel residue to ensure primer and topcoat will properly stick to surface. Rinse completely with clean water and let area dry. Crevices and seams will take longer to dry, so make sure all moisture is gone before continuing. Be very careful to keep surface free of dirt, dust, fingerprints and other contaminants after cleaning.

PRETREATMENT

WARNING



Wash down additive concentrate can cause eye irritation. Wear chemical splash proof goggles, and a face shield if needed, when mixing or when using at full strength. Failure to do so may cause death or injury to personnel. If material contacts eyes, flush with plenty of fresh water for 15 minutes and get immediate medical attention.

If old paint is sound and you did not have to sand to bare metal, you do not need pretreatment. Otherwise, immediately coat all bare metal surfaces with a coat of Primer, (Wash), Pretreatment (Formula No.117 for Metals) (Metric), DOD-P-15328 for steel surfaces, or Coating Compound, Metal Pretreatment, Resin-Acid (ASG) MIL-C-8514. The wash primer protects surface and will help primer bond to it. A sponge gives better control for this application.

PRIMER APPLICATION

WARNING



Protect eyes from splashes when mixing and applying paint. Avoid inhalation of paint fumes. Paint only in areas of adequate ventilation. Wear a respirator when mixing or applying paint if adequate ventilation cannot be obtained. Failure to do so may result in death or injury to personnel.

- a. Clean and degrease surface to be primed.
- b. Stir each component of primer before mixing, to make sure that it is uniform throughout. Then mix each part of primer together in a clean container in the ratio as described on can label or data sheet. Try to mix only enough primer that will be used before pot life expires.
- c. After thorough mixing of primer, wait for induction time, of at least a minimum of thirty (30) minutes, as stated on can label or data sheet .d. Following induction time, stir paint and apply primer to prepared area using a brush or roller. Do not apply primer too thick or it may crack during drying.
- e. After applying primer, allow primer to dry hard for thirty (30) to ninety (90) minutes or for time specified in Manufacturer's instructions, before applying topcoat. Protect surface from moisture and contamination during this period.

PRIMER

After pretreatment coating is dry, at least (thirty) 30 minutes, but no more than 24 hours, apply a coat of WD primer.

WARNING



Protect eyes from splashes when mixing and applying paint. Avoid inhalation of paint fumes. Paint only in areas of adequate ventilation. Wear a respirator when mixing or applying paint if adequate ventilation cannot be obtained. Failure to do so may result in death or injury to personnel.

Mixing

Mixing instructions for primer will depend on the type used.

- a. MIL-DTL-0053030. This epoxy primer is intended for steel or aluminum surfaces and consists of two components. Component A is a pigmented polyamide while component B is a clear epoxy. Stir component A until it is uniform in texture. Then mix one part of component B with three parts of component A. Stir until the mixture is smooth. Thin the WD primer with deionized water, 6170-19-5. You can also use distilled water. Follow Manufacturer's instructions on how much water can be safely added. Once mixed, allow WD primer to stand for thirty (30) minutes before use. The WD primer will harden in about six hours, so only mix up what you need.

b. MIL-DTL-0053022. This epoxy primer is intended for steel or aluminum surfaces and consists of two components. Component A is a pigmented polyamide while component B is a clear epoxy. Stir component A until it is uniform in texture. Then mix one part of component B with four parts of component A. Stir until mixture is smooth. Follow Manufacturer's instructions on how much solvent can be safely added, if needed. Once mixed, allow primer to stand for thirty (30) minutes before use. The primer will be ready to paint within thirty (30) minutes or when solvents have flashed off. Two (2) hours is an ideal time to properly allow solvents to flash off and primer to cure. Only mix up what you need since it has a pot life of six (6) to eight (8) hours.

c. MIL-PRF-85582. This epoxy primer is intended for aluminum and steel surfaces. Use either Class C2 or N for tactical ground or support equipment. It consists of two components. Component A is a pigmented epoxy resin solution while component B is the curing agent. Mix the two components in proportion specified by the Manufacturer. Thin WD primer with deionized or distilled water. Follow Manufacturers instructions on how much water can be safely added. Once mixed, allow WD primer to stand for thirty (30) minutes before use. The WD primer will harden in about four (4) hours, so only mix up what you need.

Application

Use a paint brush to apply the WD primer. The coating should be 1.0 to 1.5 mils for MIL-DTL-0053030 and 0.8 to 1.2mils for MIL-PRF-85582. After application, WD primer will dry hard in about five (5) to six (6) hours. High humidity and low temperatures will slow drying process. Refer to Figure 7-2 below.

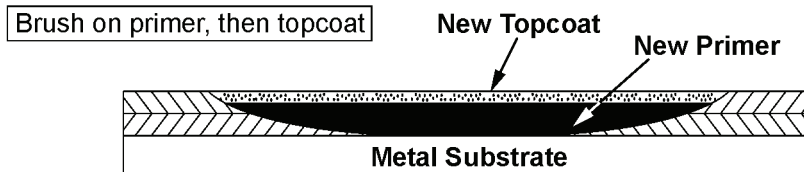

Figure 8-2

Figure 7-2. WD Primer Application

TOPCOATING WITH CHEMICAL AGENT RESISTANT COATING (CARC)**WARNING**

CARC topcoat paint contains isocyanides (ICN), which can trigger an allergic reaction in some people (lasting a few days to a few months) producing asthmatic like symptoms such as coughing, wheezing, tightness in the chest, shortness of breath including reddening of the skin, eyes and itching. If you are or become sensitized to CARC paint never use or apply CARC paint even if the above symptoms are minor. Observe the following precautions to ensure the safety of personnel when CARC paint is applied.

CARC provides both chemical agent resistance along with camouflage. Two types of CARC are used:

CAUTION

MIL-PRF-22750 is an epoxy paint and must not be used on exterior of vehicles as a substitute for MIL-DTL-53039. Epoxy paints will chalk when exposed to sunlight.

Exterior Use

One part MIL-DTL-53039, Coating, Aliphatic Polyurethane, Single Component, Chemical Agent Resistant.

- a. Stir paint to a smooth consistency. Make sure any pigment that has settled to bottom of container is evenly mixed.
- b. Do not use any paint that contains grit, coarse particles, skimming, or has excessive thickness.
- c. Once opened, this paint must be used within eight (8) hours.

TOPCOATING WITH CHEMICAL AGENT RESISTANT COATING (CARC) - (cont)

Interior Use

Two parts MIL-PRF-22750, Coating, Epoxy, High-Solids.

- Thoroughly stir each component of this two-part paint separately before mixing them. If a component shows pigment flotation, coarse particles, or settling that cannot be evenly dispersed, it should not be used.
- Do not mix components together that are from two different Manufacturers, lots, colors, or batch numbers.
- Always add component B to component A. The mixing proportions may be different depending on paint Manufacturer.

For planning purposes, typical drying and curing times for two types of CARC are given in Table 7-1 below. For touch-up painting, time needed before a vehicle or component can be returned to service should be based on good judgment relative to what areas were painted and how item will be used; dry to handle time should be used as a minimum.

NOTE

These drying times are approximate, as temperature, humidity, and air circulation all affect drying and curing rates.

Table 7-1. CARC Curing Times

Condition	Exterior MIL-DTL-53039	Exterior MIL-DTL-64159	Interior MIL-PRF-22750
Dry to touch	30 minutes	30-60 minutes	1-4 hours
Dry to handle	2-3 hours	2-3 days	4-8 hours
Complete cure	7-14 days	14 days	7 days

General procedures are provided below:

- a. Ensure surface previously primed is still clean and dry. If epoxy primer was applied more than five days ago, lightly "scuff sand" primed surface to roughen it using abrasive mats or cloth. Any dust created by scuff sanding must be removed prior to painting.

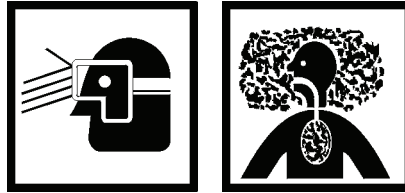
WARNING

Protect eyes from splashes when mixing and applying paint. Avoid inhalation of paint fumes. Paint only in areas of adequate ventilation. Wear a respirator when mixing or applying paint if adequate ventilation cannot be obtained. Failure to do so may result in death or injury to personnel.

- b. Mix and apply CARC topcoat in accordance with instructions contained on paint container or data sheet, and guidelines given below.

TOPCOATING WITH WD CARC**WARNING**

CARC topcoat paint contains isocyanides (ICN), which can trigger an allergic reaction in some people (lasting a few days to a few months) producing asthmatic like symptoms such as coughing, wheezing, tightness in the chest, shortness of breath including reddening of the skin, eyes and itching. If you are or become sensitized to CARC paint never use or apply CARC paint even if the above symptoms are minor. Observe the following precautions to ensure the safety of personnel when CARC paint is applied.

WD CARC topcoat paint is a two-part waterborne polyurethane coating. CARC topcoat meets all camouflage and chemical agent resistance requirements, in accordance with MIL-DTL-64159, Coating, Water Dispersible Aliphatic Polyurethane, Chemical Agent Resistant.

Factors Affecting Application of WD CARC

- Apply only when air and substrate temperatures are 40 – 95°F (4 – 35°C).
- Do not apply in rain, wind, snow, fog, or mist, or when moisture is condensing on substrate.
- Apply only when relative humidity is 85 % or below.

The pot life of CARC topcoat at 75°F (24°C) is approximately four (4) hours. The pot life will vary with temperature: approximately one (1) hour at 95°F (35°C) and six (6) hours at 40°F (4°C).

The minimum time to recoat CARC over itself is six (6) hours at 75°F (24°C). This also varies with temperature: approximately five (5) hours at 95°F (35°C) and twelve (12) hours at 65°F (18°C).

Chemical Agent Resistant Coating (CARC) topcoat tends to dry and cure much faster than other paints you may be familiar with. If they dry too fast, surface will become hard and small bubbles or blisters may form as carbon dioxide gas tries to escape from coating as it cures. Therefore, here are some special notes about applying CARC.

- Try to avoid painting hot metal surfaces.
- Avoid painting in direct sunlight.
- Try to avoid painting when it is very breezy or windy

Application of WD CARC Topcoat**WARNING**

CARC topcoat paint contains isocyanides (ICN), which can trigger an allergic reaction in some people (lasting a few days to a few months) producing asthmatic like symptoms such as coughing, wheezing, tightness in the chest, shortness of breath, including reddening of the skin and eyes, and itching. If you are or become sensitized to CARC paint never use or apply CARC paint even if the above symptoms are minor. Observe the following precautions to ensure the safety of personnel when CARC paint is applied:

Once WD primer is dry, it is time to apply WD CARC topcoat. WD CARC is available in bulk kits or self-contained touch-up kits. Select the WD CARC application that best fits your situation. All of the following information applies to both Type I and Type II WD CARC. The kits are approved and recognized as Type III for MIL-DTL-64159. Efforts are ongoing to include touch up kits for MIL-DTL-53039 solvent-based CARC. However, touch up kits are currently available only for the WD CARC version.

Mixing**WARNING**

Protect eyes from splashes when mixing and applying paint. Avoid inhalation of paint fumes. Paint only in areas of adequate ventilation. Wear a respirator when mixing or applying paint if adequate ventilation cannot be obtained. Failure to do so may result in death or injury to personnel.

WD CARC comes in two component kits that have to be mixed before use. Component A is a hydroxyl functional polyurethane that includes pigments, additives and solvents. Component B is an aliphatic isocyanine prepolymer. The mixing ratio is two parts of component A to one part of component B. Once the two components are thoroughly mixed, you can thin the paint by adding deionized water. Follow the manufacturer's recommendation on how much water can be safely added. Be careful not to over thin with water since that will make the paint unusable. Again, you must thoroughly mix the paint to ensure the water and both components are completely blended.

Application of WD CARC Topcoat (continued)**CAUTION**

There are a number of steps to follow when you spot paint with the WD CARC system. If you skip a step or take a shortcut, you'll end up with a coating that peels easily or one that bubbles up and falls off.

Application

Use a paint brush or roller to apply the WD CARC to a thickness of 1.8 to 2.5 mils. Cure time will increase with low temperatures and high humidity, and decrease with higher temperatures and low humidity. At an optimum temperature of 70°F (21°C), Type I WD CARC will dry to touch in approximately fifty (50) minutes, dry hard in four (4) hours, dry through in five (5) hours, and completely cure within seven (7) days. Type II WD CARC will dry to touch in approximately sixty (60) minutes, dry hard in six (6) hours, dry through in eight (8) hours, and completely cure within seven (7) days.

Touch-up Kits

WARNING

Dried spray-paint dust can pose an extreme fire hazard. Remove and dispose of this dust daily in accordance with AR 420-47. The danger of fire can be materially reduced by the use of a water-wash or waterfall type of spray booth. Failure to do so may result in death or injury to personnel.

Army Research Labs has tested and validated self-contained touchup kits for use where touch-up or stenciling is needed. These kits are available as an aerosol or as a non-aerosol with a sponge roller or brush applicator. Refer to Tables 21-10 thru 21-12 of WP 0021 00, of this Technical Manual (TM). An identical color match with touch up kits is not required. Colors that are lighter or darker are acceptable as long as qualified products are being used.

CLEAN-UP AND DISPOSAL FOLLOWING PAINT APPLICATION**WARNING**

Solvents are flammable and toxic. Use only in well ventilated spaces. If ventilation cannot be provided and work would result in breathing solvent vapors, wear air-purifying respirator equipped with organic vapor cartridge. Do not use near open flames or sources of sparks. Do not smoke in the area where solvents are being used. Do not allow prolonged contact of solvent with bare skin. Failure to do so may result in death or injury to personnel.

CAUTION

- Cleanup water cannot be placed in a sanitary sewer and must be disposed of according to local hazardous waste procedures.
- Cleanup liquids and/or unused paint must be segregated for disposal.
- Carbon dioxide will be generated during curing of paint and container must be vented to avoid a pressure build up.

Paint brushes and rollers can be cleaned with soap and water. It is recommended that rubber gloves be worn when cleaning these items.

DRYING AND STORAGE OF FRESHLY PAINTED EQUIPMENT

When paint topcoats described above are said to have dried to touch, it means they have reached a point where a finger pressed or rubbed against paint film will not have any paint adhere to your finger. At this point, equipment is safe to move to an appropriate staging area. Equipment should be protected from falling or blowing dirt, debris, or rain and snow.

PAINT STORAGE

In most locations, paints will be required to be stored in accordance with local Hazardous Material storage requirements. However, paints generally have some special storage requirements, summarized below.

- Store paint away from heat, sparks, or open flames.
- Store in tightly closed containers, and protect from moisture so that metal paint cans do not corrode.
- Paints should be stored in a climate controlled environment in the temperature range of 45 - 110°F (7 - 43°C).
- Containers must be protected from freezing. If paint has been exposed to freezing conditions, it should be examined for a change in physical characteristics. If material has appearance of cottage cheese, or curdling, seeding, or grit is observed, it should not be used.

PAINT STORAGE (continued)

- The Part B clear component of CARC should be kept airtight. If not, material will react with moisture in air and form carbon dioxide gas. As a result, the container may swell. Upon opening container, there will be a popping sound. The material may be cloudy or gelled. Material in this condition should not be used. The shelf life for unopened containers is one (1) year from date of manufacture, not date received. The contents of any partially opened containers should be used as soon as possible.

UNUSED PAINT

Treat any leftover wash primer, WD primer or WD CARC as hazardous waste. If it has hardened, seal it and dispose of it properly. Your unit SOP should address how to handle hazardous waste. You can also find disposal information in the Material Safety Data Sheets or at your local Environmental Office.

END OF WORK PACKAGE

CLEANING AND TREATMENT OF SURFACES

SCOPE

This Work Package (WP) covers material to be used and procedures to be followed in cleaning, and treatment, of surfaces for painting of equipment to provide protection against rust, corrosion, detection, and/or deterioration. For more information on specific systems not addressed in this WP, refer to applicable finishing documents such as MIL-STD-171, Finishing of Metal and Wood Surfaces, MIL-DTL-14072, Finishes for Ground Based Electronic Equipment, and TT-C-490, Chemical Conversion Coatings and pretreatment for Ferrous Surfaces (base for organic coatings).

SURFACE PREPARATION

Surfaces to be painted must be thoroughly cleaned. All rust, corrosion products, oil, grease, moisture, dirt, fouling organisms, loose and blistered paint, deteriorated areas of old paint, and other surface contaminants will be removed prior to painting. Surfaces that require removal of loose paint shall be prepared in the following manner:

- The initial step shall be to remove all loose paint by light sand blasting or orbital sanding.
- The edges of good paint surrounding prepared areas shall be feathered using abrasive sanding disks or stainless steel scouring pads.
- The newly cleaned areas shall be washed with liquid detergent cleaner, and thoroughly rinsed with fresh water until surface can pass a water break test. The surface shall be allowed to dry completely; pretreatment should begin within four hours after cleaning.

Paint Remover

Paint remover will conform to a low viscosity, for horizontal surfaces, and a high viscosity, to be used for vertical and near vertical surfaces. These paint removers will have minimal effect on Chemical Agent Resistant Coating (CARC) coated surfaces. However, for CARC coated surfaces use paint remover, according to Manufacturer's instructions.

Solvent Cleaning**WARNING**

Solvents are flammable and toxic. Use only in well ventilated spaces. If ventilation cannot be provided and work would result in breathing solvent vapors, wear air-purifying respirator equipped with organic vapor cartridge. Do not use near open flames or sources of sparks. Do not smoke in the area where solvents are being used. Do not allow prolonged contact of solvent with bare skin. Failure to do so may result in death or injury to personnel.

Surfaces intended for conventional paint will be cleaned with currently approved cleaning agents. Surfaces intended for CARC coatings will be cleaned in accordance with TT-C-490. Metal surfaces intended for vinyl paints will be cleaned with ASTM D 329, Acetone. Mineral spirit type solvents will not be used on surfaces to be coated with paint because these solvents leave an oily film which interferes with proper adhesion.

For equipment without a data plate, thoroughly wet a rag with acetone (i.e. fingernail polish remover) and briskly rub the painted surface for 20 seconds. Evidence of actual paint removal onto rag indicates an alkyd painted surface.

CLEANING OF SPECIFIC SURFACES

Unless otherwise stated in the end item specification, cleaning shall be accomplished by chemical methods (such as solvent cleaning, alkaline cleaning, acid cleaning, pickling, descaling with hydride or paint stripping), by electromechanical cleaning methods (such as electro polishing, electrolyte alkaline, or electrolytic pickling), or by mechanical means such as blasting, chipping, wire brushing, or grinding. After cleaning, all surfaces shall be kept free from dirt, dust, finger marks, and other contaminants. Various surfaces, such as ferrous metals, zinc, aluminum and aluminum alloy, magnesium alloy, wood, and previously painted surfaces, require special handling.

Ferrous Metal Surfaces

Unless otherwise specified, ferrous metal surfaces to be painted shall be blast cleaned in accordance with Steel Structural Painting Council (SSPC) Specification SPC6 to remove millscale, products of corrosion, dirt, casting, sand, slag, and other foreign substances. Also, when stated, blast-cleaning shall be in accordance with specifications SPC-5 or SPC-10, as required (see Steel Structures Painting Council Manual, SPC6 for more information). Blast-cleaned surfaces shall be given a prime coat as soon as possible after cleaning and in no case more than four hours later. Blast-cleaning shall not be used on surfaces which could be damaged, such as machine parts and sheet metal, thinner than 0.0625 inch (16 gage U.S. Standard).

Ferrous Metal Surfaces (continued)

Blast-cleaning is optional on components painted for protection during limited storage, from which paint will be worn off as soon as equipment is placed in use. Examples are truck assemblies, track roller assemblies (including mounting frames), interiors of weld-type box sections, bulldozer components (including rippers, scarifiers, ejectors, push plates, blades, bowls, and buckets), scrapers and crane shovels, interiors of cement mixer drums, and interiors of aggregate driers. However, these surfaces shall be dry and free from oil, grease, dirt, corrosion, and rust prior to painting.

Other surfaces that cannot be cleaned by blasting may be cleaned to base metal by chipping, powered wire brushing, or grinding to the required degree specified above for commercial sand blasting. Sheet metal and sheet metal parts of eight gage and thinner may be cleaned to bare metal by acid pickling in accordance with TT-C-490, Chemical Conversion Coatings and Pretreatments for Ferrous Surfaces, with a maximum of five percent sulfuric acid included. Old paint may be removed from vehicles requiring repainting by the use of a paint remover.

Zinc Surfaces

Zinc surfaces, including zinc-coated ferrous material, shall be thoroughly cleaned, as specified above, to remove all traces of oil, grease, dirt, and other foreign substances.

Aluminum and Aluminum-Alloy Surfaces

These surfaces shall be thoroughly cleaned, to remove all traces of oil, grease, dirt, and other foreign substances. This shall be followed by a three to five minute immersion or pressure spray in a hot, 10 % solution of chromic acid, after which the surfaces shall be thoroughly rinsed with clean, warm water to remove excess chromic acid from cavities, joints, and recesses. The concentration of chromic acid shall be checked at regular intervals to ensure that solution is maintained at specific strength. Aluminum surfaces that cannot be immersed or sprayed with chromic acid shall be mechanically cleaned, swabbed with a solution of MIL-DTL-5541, Chemical Conversion Coatings on Aluminum and Aluminum Alloys.

Magnesium Alloy Surfaces

Magnesium alloy surfaces shall be cleaned in accordance with SAE-AMS-M-3171, Magnesium Alloy, Processes for Pretreatment and Prevention of Corrosion On.

Wood Surfaces

Wood surfaces to be painted shall be dry and cleaned of all dirt, oil, grease, and other foreign substances with a straight, petroleum-aliphatic solvent.

Previously Painted Surfaces

Any coating showing corrosion, cracking, blistering, or flaking must be sanded down to bare substrate and solvent cleaned. Consider such surfaces bare and treat as required.

For Chemical Agent Resistant Coating (CARC) application over CARC

CARC may be applied over sound CARC surfaces that have been solvent cleaned. Items painted with CARC will not normally require stripping. Exceptions are corroded areas with severe weight restrictions. These surfaces shall be cleaned of paint by Plastic Media Blasting (PMB) at 40 Pounds Per Square Inch (PSI), whenever possible. This is preferred method of removing CARC primers and enamels. After paint removal, entire surface will be cleaned and tested for cleanliness using a water break or red litmus test.

For application of other finish systems

Previously painted surfaces that are to be painted with finish systems other than CARC should follow requirements and procedures of individual finish systems and specifications involved.

SURFACE TREATMENT

Bare metal surfaces to be painted with CARC coatings or vinyl paints will be coated immediately after cleaning with pretreatment wash primer where applicable. This pretreatment will be used under conventional paints only where specified. This wash primer will not stick to steel surfaces which have been treated with metal conditioner. Aluminum may require pretreatment with MIL-DTL-5541, Chemical Conversion Coatings on Aluminum and Aluminum Alloys.

TREATMENT OF SPECIFIC SURFACES

Pretreatment of surfaces is generally used as a bonding agent between surface of equipment and follow-on coatings. It provides temporary protection against corrosion.

Ferrous Metal, Zinc, or Cadmium Surfaces

Ferrous metal, zinc, or cadmium surfaces shall be treated as soon as possible after cleaning, as follows:

- With an organic pretreatment primer, or with a zinc phosphate (Type I) or iron phosphate (Type II) chemical conversion containing in accordance with TT-C-490, Chemical Conversion Coatings and Pretreatments for Ferrous Surfaces (base for organic coatings).
- Any evidence of rust or contamination on a previously cleaned surface shall be cause for recleaning prior to painting.

Aluminum Surfaces

Aluminum surfaces shall be treated as soon as possible after cleaning, as follows:

- With an organic pretreatment wash primer in accordance with MIL-A-8625, Anodic Coatings for Aluminum and Aluminum Alloys, or MIL-DTL-5541, Chemical Conversion Coatings on Aluminum and Aluminum Alloys.
- Any evidence of corrosion or contamination on previously cleaned surfaces shall be cause for recleaning prior to painting.

TREATMENT OF SPECIFIC SURFACES (continued)**Magnesium Alloy Surfaces**

Prior to painting, magnesium alloy surfaces shall be treated in accordance with SAE-AMS-M-3171, Magnesium Alloy, Processes for Pretreatment and Prevention of Corrosion On, Type I or III. Treated surfaces that become scratched in handling shall be touched up in accordance with SAE-AMS-M-3171, Type I.

Wood Surfaces

Properly seasoned wood shall be sealed prior to application of Chemical Agent Resistant Coating (CARC) with a polyurethane sealer. Glue used during construction with wood shall be treated with sealer after construction. Unless otherwise specified, wood shall be treated prior to sealing, and dried to a moisture content no greater than 20%, and pressure treated in accordance with American Wood Preservers Bureau (AWPB) LP-2 (above ground) or LP-22 (ground contact). Alternate processes are available when repainting or when pressure treatment is not available.

Hardware and Hardware Items

Hardware and hardware items such as bolts, cap screws, washers, pins, springs, and grease fittings are not to be cleaned and treated prior to assembly and painting if there is no evidence of corrosion.

Corrosion-Resisting Steel Surfaces

Corrosion-resisting steel surfaces shall be cleaned, then treated as follows (unless corrosion-resisting steel has already been passivated and has not been contaminated or depassivated by working, forming, or shaping end item). The process specified below is primarily a passivating treatment for corrosion resisting steels and is not a cleaning treatment.

- Immerse for thirty (30) minutes in a solution containing 20 % by volume of nitric acid and two percent by weight of sodium dichromate at 120°F (49°C) to 130°F (54°C).
- Rinse in clean hot water.
- Immerse for one hour in a solution containing five percent by weight of sodium dichromate, at 140°F (60°C) to 160°F (71°C).
- Rinse in clean hot water.
- Rinse in hot water at 160°F (71°C) to 210°F (99°C), with rinse maintained at pH 3 to pH 5 by addition of flake chromic acid or proprietary mixtures of chromic and phosphoric acid. Surfaces to be painted shall be treated with wash primer conforming to MIL-C-8514, Coating Compound, Metal Pretreatment, Resin-Acid (ASG).

END OF WORK PACKAGE

PAINTING

SCOPE

This Work Package (WP) covers material to be used and procedures to be followed for painting with Chemical Agent Resistant Coating (CARC) and non-CARC painting systems.

PAINTS

Paints are mechanical mixtures or dispersions of pigments in a nonvolatile liquid. A volatile solvent or thinner is used to reduce paint to proper consistency for application. The pigmented liquid, after application to surface by brushing, spraying, or dipping, dries to form a solid and opaque coating. An oil paint contains a drying oil or oil varnish as the basic ingredient. Paste type paint is one that permits a substantial addition to the vehicle of thinner to obtain consistency required for application. Asphalt paint contains asphalatum or a similar substance as the principal nonvolatile ingredient; this also provides the coloration of black or brown.

APPLICATION

The first coat of paint or primer shall be applied to a dry, clean surface as soon as is practical. Coatings shall be applied in an ambient temperature of 50°F (10°C), or higher. Paint and surface shall be approximately the same temperature except when hot spray is used. Paint shall be applied by any method (dip, flowcoat, brush or spray) which will deposit dry film coat-thickness specified in Table 9-1. Panels or subassemblies prepainted prior to final assembly shall be treated and painted as specified herein. A smooth, even surface, free from runs, sags, or other defects which might interfere with application and adhesion of subsequent coats, shall be applied. When applying priming coat, sufficient time must be allowed for paint to dry prior to applying finish coat. Baked finishes, except on materials that would be adversely affected by such treatment, will be permitted if baked finish conforms to performance requirements of applicable paint specification.

DRY FILM THICKNESS

The upper limits on film thickness are not mandatory for surface areas on which such limits are impractical to maintain; for example, contoured areas. However, film thickness should be controlled in these areas, to prevent excessive deposition of paint. Film thickness tests shall be performed on uniform coated surfaces. Thickness testing shall be performed using a conventional nondestructive measuring device or other acceptable standard methods. Recommended thickness requirements for CARC primers and topcoats are listed in Table 9-1. For other coatings, reference individual specifications.

Table 9-1. Dry Film Thickness (Mils)

DOD-P-15328	0.3-0.5
MIL-PRF-22750	1.3-1.7
MIL-C-8514	0.3-0.5
MIL-DTL-64159	1.8-2.5
MIL-DTL-53039	1.8-2.5
MIL-P-53084	1.0-1.2
MIL-DTL-0053022	1.0-1.5
MIL-DTL-0053030	1.0-1.5

APPLICATION OF THE CARC SYSTEM

WARNING



CARC topcoat paint contains isocyanates (ICN), which can trigger an allergic reaction in some people (lasting a few days to a few months) producing asthmatic like symptoms such as coughing, wheezing, tightness in the chest, shortness of breath, including reddening of the skin and eyes, and itching. If you are or become sensitized to CARC paint never use or apply CARC paint even if the above symptoms are minor. Observe the following precautions to ensure the safety of personnel when CARC paint is applied:

Application of Chemical Agent Resistant Coating (CARC) system consists of four distinct steps, each of which is critical to performance of overall system; cleaning, pretreating, priming, and topcoating. The cleaning and pretreating procedures are standard methods required in any finishing process. When a wash primer pretreatment is used, drying/reaction must be complete when used under CARC. Otherwise adhesion and CARC system may be adversely affected. The anticorrosive primers are epoxies, and topcoats are polyurethanes for exterior surfaces and an epoxy for interior surfaces. All coatings in the CARC system are Qualified Products List (QPL) items; that is, there is a list of approved suppliers which must be used for product procurement. In addition, each batch of polyurethane topcoat must be checked by the Specification Preparing Activity (SPA) for validation of the spectral reflectance (camouflage properties) and DS2 resistance. The local Safety Office, Preventative Medicine activity, and local medical support facility must be consulted prior to initiating CARC application. For guidance, refer to MIL-DTL-53072, Chemical Agent Resistant Coating (CARC) System Application Procedures And Quality Control Inspection. Pertinent specifications are listed in Table 9-2.

TABLE 9-2. The CARC System

Process	Ferrous Metal	Non-Ferrous Metal
Cleaning	TT-C-490	TT-C-490
Pretreating	TT-C-490, I (Zn phosphate) DOD-P-15328 (wash primer) MIL-C-8514 (wash primer)	DOD-P-15328 (wash primer) MIL-C-8514 (wash primer) MIL-DTL-5541 (chromate conversion) MIL-A-8625 (anodize)
Priming	MIL-DTL-0053022 MIL-DTL-0053030 MIL-P-53084	MIL-DTL-0053022 MIL-DTL-0053030 MIL-P-53084
Topcoating	MIL-PRF-22750 (interior only) MIL-DTL-53039 MIL-DTL-64159	MIL-PRF-22750 (interior only) MIL-DTL-53039 MIL-DTL-64159

Cleaning

Improperly cleaned surfaces are unacceptable because they limit or interfere with paint adhesion, causing subsequent paint loss in service, which will leave the substrate unprotected from environment. Unless otherwise specified, surface should be thoroughly cleaned according to TT C-490, Chemical Conversion Coatings and Pretreatments for Ferrous Surfaces (Base for Organic Coatings). Method of cleaning is determined by base material properties, nature of soil and degree of contamination and by use of any methods or combination methods listed below:

WARNING



Solvents are flammable and toxic. Use only in well ventilated spaces. If ventilation cannot be provided and work would result in breathing solvent vapors, wear air-purifying respirator equipped with organic vapor cartridge. Do not use near open flames or sources of sparks. Do not smoke in the area where solvents are being used. Do not allow prolonged contact of solvent with bare skin. Failure to do so may result in death or injury to personnel.

- Chemical methods (such as solvent cleaning, alkaline cleaning, acid cleaning, pickling, descaling with hydride or paint stripping).

- Electrochemical cleaning methods (such as electropolishing, electrolyte alkaline, or electrolytic pickling).

WARNING



Power tools can cause hand or eye injury and may produce high noise levels and airborne dust. These tools can create flying debris – use impact resistant eye protection. Follow all safety precautions for the power tool used. Do not defeat or disable any safety mechanisms. Failure to do so may result in death or injury to personnel.

- Mechanical means such as blasting, chipping, wire brushing, or grinding.

Cleaning materials/methods, which may be effective against one type of contaminant, may be ineffective against others; therefore, multiple cleaning methods may be required to provide a clean surface. Detergents or solvents must be used to remove soil prior to abrasive blasting or mechanical cleaning. Surface oxides, rust weld spatter and other inorganic contaminants shall be removed prior to pretreatment using appropriate mechanical/chemical cleaning methods. After cleaning, all surfaces shall be kept free from dirt, dust, finger marks, and other contaminants. Meticulous cleaning prior to pretreatment and painting operations cannot be overemphasized since this factor is of prime importance in obtaining a satisfactory coating meeting requirements of this Work Package (WP).

PRETREATING

WARNING

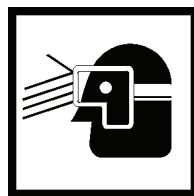

Wash down additive concentrate can cause eye irritation. Wear chemical splash proof goggles, and a face shield if needed, when mixing or when using at full strength. Failure to do so may cause death or injury to personnel. If material contacts eyes, flush with plenty of fresh water for 15 minutes and get immediate medical attention.

CLEANING (continued)

Chemical surface treatments for metallic substrates provide improved adhesion for subsequent coatings and temporary protection from corrosion. For best results, pretreatment shall be applied as soon as possible after proper cleaning. The two most common types are straight conversion (either chromate or phosphate) and organic (vinyl wash primer) modified conversion.

PRIMING

Primer shall be applied to a clean, dry surface as soon as possible after cleaning and pretreating. The ambient temperature should be between 60 and 90°F (15.6 and 32.2°F), but primers may be applied outside this range without adverse effects, provided appropriate Quality Control checks are performed in accordance with MIL-DTL-53072, Chemical Agent Resistant Coating (CARC) System Application Procedures And Quality Control Inspection. The paint and surface shall be approximately the same temperature, and application shall be by brush or spray, depositing a continuous, adherent, dry film which is smooth, even, and free from runs, sags, or other defects which might interfere with application and adhesion of subsequent coats in accordance with MIL-DTL-53072. If paint heaters are used to assist in application, substrate to be coated must be at least at an ambient temperature of 60°F (15.6°C). Dipcoating is not recommended for CARC primers. The five anticorrosive primers are epoxies, and all are two component products. They are applied to metal substrates to provide corrosion resistance and a surface to which the CARC topcoat will firmly adhere. As two component products, they dry by a two stage process of solvent evaporation and chemical crosslinking, and they have a finite potlife, typically eight (8) hours. Environmental conditions, particularly temperature and relative humidity, will affect potlife, curing, and adhesion.

TOPCOATING

The three CARC topcoats provide chemical agent resistance and color for system. In addition, polyurethanes (exterior surfaces) provide camouflage protection to visible and near infrared means of detection, while epoxy (interior surfaces) provides a smooth, easily cleaned surface which is resistant to wear. These coatings also offer improved performance and prolonged service life. The CARC topcoats inhibit absorption of chemical agents into paint film and allow decontamination process to be simplified. It is best to apply topcoat to a freshly primed substrate within twenty four (24) hours. The drying time between priming and topcoating should be no more than 168 hours, but in no case less than minimum time specified for recoating test of material specifications.

If topcoating proceeds after 168 hours, either scuff sanding followed by a solvent wipe or a primer mist coat is required. Adhesion testing shall be used to monitor inner coat adhesion. As with CARC primers, application should be by brush or spray, paint and substrate should be approximately the same temperature, and ambient temperature should be between 60 and 90°F (15.6 to 32.2°C) at application and for a period of time after application sufficient to assure adequate cure prior to exposure to adverse conditions. For ordering information National Stock Number (NSN) refer to WP 0024 00; National Stock Number (NSN) Tables, of this Technical Manual (TM).

COATINGS FOR HIGH TEMPERATURE SERVICE

When surfaces being painted will reach service temperatures over 350°F (177°C), and up to 1400°F (760°C), Chemical Agent Resistant Coating (CARC) paints cannot be used. This includes items such as vehicle exhaust systems, manifolds, mufflers, and turbochargers. Use Heat Resistant Paint, MIL-P-14105 for these areas.

In general, these coatings require a clean, dry surface for best performance. Clean parts to be coated to remove any oil or grease, and remove all old paint and as much corrosion as possible using hand or power tool cleaning. Depending on exact coating being used, heating coated surface may be needed to get best performance. If there is access to an oven, and if coated parts are removed from vehicle and of a proper size, using an oven to bake coating will give best control of process. Otherwise, after coating has air-dried, run vehicle engine to allow exhaust system to heat up. Refer to product data sheet for coating being used.

CAUTION

Mask intake and exhaust ports, breathers, etc., carefully to prevent dust, solution, water, or metal conditioner from entering engine.

Chemical Agent Resistant Coating (CARC) should be used on all surfaces, interior and exterior, of tactical (combat, combat support and ground support) equipment where temperature does not exceed 400°F. This would include engine compartments, for example. The type and color for interior should be specified to facilitate maintenance or human factors engineering considerations.

Engines, engine components, and powertrain assemblies which are normally painted should be painted consistent with above paragraph. For areas that exceed 400°F, paint should conform to MIL-P-14105, Paint, Heat Resisting (for Steel Surfaces) as applicable. Generally, this means that exposed engines (e.g., on a road grader) or engine components should be painted with MIL-P-14105 in a camouflage pattern compatible color. While intended use of MIL-P-14105 is on ferrous substrates, it will work on aluminum, but performance limit of coating (1400°F, 760°C) is well above melting point of aluminum. Coating should not be used with a primer.

Engine Compartments: All exterior surfaces of combat vehicle engine compartments not exposed to outside view shall be painted white or light green for better reflection of light.

TECHNIQUES OF MIXING AND THINNING**Method**

The best, quickest, and easiest method of painting is by spraying. Paint rollers are used on large surfaces when spraying is impractical. Paints are brushed on when other methods are impractical or special equipment is not available. In general, use of brushes is confined to touchup jobs.

TECHNIQUES OF MIXING AND THINNING (continued)**Readiness**

In most cases, paints are issued ready mixed; hence color blending is not required. Chemical Agent Resistant Coating (CARC) paints in accordance with MIL-PRF-22750, Coating Epoxy, High-Solids, however, are issued in a two-component form and require accurate mixing techniques.

WARNING

Protect eyes from splashes when mixing and applying paint. Avoid inhalation of paint fumes. Paint only in areas of adequate ventilation. Wear a respirator when mixing or applying paint if adequate ventilation cannot be obtained. Failure to do so may result in death or injury to personnel.

Stirring

Stir paints well before use. If vehicle (liquid portion) has separated from pigment, pour off most of liquid portion into a clean container. Stir thick settled portion (pigment) in bottom until all chunks are softened and dissolved. Restore poured off portion a little at a time, stirring constantly with a lifting and beating motion. "Box" paint thoroughly by pouring it from one container to another several times, stirring paint for a few minutes between each transfer.

STORAGE OF PAINT MATERIALS (continued)**Straining**

When paint stands over a period of time, a skin may form over surface and pigment may form into chunks to extent that stirring will not mix all ingredients properly. In such cases, strain paint through a strainer into a clean container, discarding residue left on strainer. Do not strain CARC coatings, however. CARC coatings which cannot be properly mixed will be resealed and disposed of as hazardous wastes.

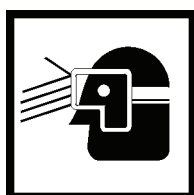
WARNING

Paint thinners can cause eye irritation. Wear chemical splash proof goggles, and a face shield if needed, when mixing or when using at full strength. Failure to do so may cause death or injury to personnel. If material contacts eyes, flush with plenty of fresh water for 15 minutes and get immediate medical attention.

NOTE

Polyurethane coatings may be thinned using Thinner, Aircraft Coating, MIL-T-81772 or as recommended by Manufacturer instructions.

Thinning

When it is necessary to thin paint, use a small amount of prescribed thinner. Because of its volatility, thinner will evaporate from paint film, leaving practically same ratio of vehicle to pigment per square foot of surface as paint would have provided before thinning. The warmer and drier the weather, less thinner is needed because heat tends to thin the vehicle. More thinner is required in cold weather to hasten drying and hardening of film. Thinner should be used with care, as the less used, the more durable the applied coat will be.

STORAGE OF PAINT MATERIALS**WARNING**

Post NO SMOKING signs in paint warehouses. Failure to do so may result in death or injury to personnel.

The materials covered in this paragraph include primers, fillers, paints, and other liquid products that are required for protective finishes. Store these materials where they will be protected from the elements and extreme temperature changes. While freezing temperatures may cause a separation of some ingredients, which are difficult to mix again with uniform consistency, the majority of products described in this manual are not damaged by freezing. Chemical Agent Resistant Coating (CARC) coatings MIL-DTL-64159, Coating, Water Dispersible Aliphatic Polyurethane; MIL-DTL-53039, Coating, Aliphatic Polyurethane, Single Component; and MIL-PRF-22750, Coating, Epoxy, High Solids cannot be used after being frozen.

CAUTION

CARC paints have a shelf life of one (1) year. This one year shelf life can only be reached if CARC paint is stored at a proper temperature range of between 32°F and 120°F (0 and 48.9°C).

- Up end containers every ninety (90) days when they are stored on end, or rotate them one-half (1/2) turn every ninety (90) days when they are stored horizontally.
- Do not store partially filled containers without tightly installing lids, covers, or caps.
- Do not store paints, or other flammable materials near steam pipes, open flames, or where there is a danger of flying sparks, such as from welding equipment.
- Paint and paint thinners shall be stored separately from other materials such as grease, oil, and spare parts. Rags, wood, and similar matter shall not be stored in same area as paints and paint thinners.
- To avoid possible leakage from rusted containers, protect containers against rain, snow, steam leaks, and other sources of water.

Each container should be labeled with complete instructions as to type of material, thinning ratio, thinning material, and color, gloss, and application data. Each container should also be labeled with Safety Warnings and Cautions.

STORAGE OF PAINT MATERIALS (continued)

Maintain a perpetual inventory of all materials when volume is large enough to warrant effort. Install a system of dating for each shipment received. Use oldest stock first since aging causes certain types of coatings to lose their gloss and to thicken to such an extent that they are rendered useless. Black enamels have a particular tendency to lose their gloss and drying properties upon aging.

After shelf life of a paint has been reached, if samples of paint conform to specification requirements for viscosity, drying time, application, thinning, gloss, and color, and if condition in container reveals no excessive skimming, hard settling, or resin separation, shelf life may be extended by 50% (i.e. a one (1) year shelf life would be extended by six (6) months). This includes storage extension for Chemical Agent Resistant Coating (CARC) paints.

TIPS ON PAINTING

Certain basic precautions are applicable to paint. The following should be observed at all times:

CAUTION

If painting is to be accomplished in an enclosed area, efforts should be made to control temperature to approximately 75°F to 80°F (24°C to 27°C), and relative humidity to approximately 45 to 50%. Humidity may be lowered by raising shop temperature.

- Do not paint over an unclean surface. Be sure all dirt, corrosion, scale, etc., are removed.
- Do not fail to stir paint thoroughly.
- Do not mix one type of paint with another.
- Do not fail to follow instructions which appear on containers.
- Do not paint in wet or extremely cold weather (below 50°F (10°C)).
- Do not apply abnormally heavy coats.
- Do not use paint buckets, cans, paint rollers, spray guns, or brushes which are not clean.
- Do not leave old paint and oil-soaked cloths laying around in paint shop; they are a fire hazard.
- Do not fail to clean brushes, paint rollers, and spray guns immediately after using.
- Do not smoke when painting. Do not smoke near paint storage areas or paint booths.
- Do not release tops of pressure-feed material containers before releasing air pressure.
- Do not use electrical connections that show any inclination of becoming loose.
- Do not pour paint out of a container in a manner that obscures the label.

TIPS ON PAINTING (continued)

- Do not fail to strain paint before using, if required.
- Do not paint without proper respiratory equipment and ventilation.
- Do not waste paint by spraying behind item being coated.
- Do not paint over a moist or wet surface.
- Do not paint between ground strap and hull of tanks.
- Do not paint on operator-instruction plates.

TIPS ON PAINTING WITH CHEMICAL AGENT RESISTANT COATINGS (CARC)

The following precautions should be observed, in addition to those listed in Tips On Painting listed above, when applying CARC:

- Spray lines for epoxy applications should not be used with polyurethane coatings without complete flushing or cleaning with solvents.
- Test for cleanliness when applying CARC with a red litmus or water break test.
- Remember to notify the local Safety Office and Preventive Medicine support activity prior to initial CARC painting. This also applies to all spray painting operations, regardless of material used.
- Do not use CARC for items like manifolds and mufflers that exceed 400°F (204.4°C). Do not use CARC on rubber, lacquer coatings, or vinyl.
- Use impervious, not cloth, gloves when applying CARC.
- Do not apply CARC to flexible items. Because of its rigidity, finish may crack when bent.
- When using CARC, mix only amount needed to do job (i.e. do not open a large container for a small job) because unused CARC must be disposed of and cannot be stored.
- Epoxy-polyamide coatings build up thickness quickly. Thick films are detrimental for good adhesion. Do not apply CARC beyond its thickness tolerances.
- For more information, refer to MIL-DTL-53072, Chemical Agent Resistant Coating (CARC) System Application Procedures and Quality Control Inspection.

END OF WORK PACKAGE

SPECIFIC FINISH SYSTEMS

GENERAL

This Work Package (WP) details specific finish systems for both camouflage and non-camouflage materials. Details on each component covered can be found in Chapter 2, Undercoats, Finish Materials, and Related Products, of this Technical Manual (TM) and in individual specifications. This WP gives additional information on particular finish systems, including those using Chemical Agent Resistant Coating (CARC).

Specifications for CARC camouflage colors contain requirements to protect Military equipment against visual and infrared detection and chemical agent contamination. CARC paints have this protective ability and also the ability to be easily decontaminated. Camouflage coatings, are rough and difficult to clean under field conditions. TT-C-490 Chemical Conversion Coatings and Pretreatments for Ferrous Surfaces (Base for Organic Coatings), is very useful in cleaning camouflage (alkyd or CARC) painted equipment.

For further camouflage paint Qualified Products List (QPL) information, refer to Chapter 4, Camouflaging Procedures, of this TM, or contact: CARC Commodity Manager, U.S. Army Research Laboratory, 4600 Deer Creek Loop, AMSRD-ARL-WM-MC. Aberdeen Proving Ground, MD 21005-5069.

CHEMICAL AGENT RESISTANT COATINGS (CARC)

WARNING



CARC topcoat paint contains isocyanides (ICN), which can trigger an allergic reaction in some people (lasting a few days to a few months) producing asthmatic like symptoms such as coughing, wheezing, tightness in the chest, shortness of breath, including reddening of the skin and eyes, and itching. If you are or become sensitized to CARC paint never use or apply CARC paint even if the above symptoms are minor. Observe the following precautions to ensure the safety of personnel when CARC paint is applied:

Chemical Agents pose a devastating threat to sustained readiness in a combat environment. CARC paints were developed to minimize impact of this threat. CARC paints are relatively impermeable coatings which do not absorb/desorb chemical agents, and which do not break down when decontaminated.

CHEMICAL AGENT RESISTANT COATINGS (CARC) (continued)

A common misconception is that CARC paints present greater Health/Safety/Environmental hazards than do other paints. In fact, Health and Safety requirements for CARC are the same as those for all paints. And although CARC paints are currently more expensive and require additional care in application, their durability make overall life cycle costs/efforts less than those of other paint systems.

CAUTION

Do not mix components of MIL-DTL-64159 with MIL-DTL-53039.

NOTE

There are currently two CARC paints used for exterior surfaces, and one for interior surfaces.

- a. MIL-DTL-64159: A two-component water dispersible aliphatic polyurethane, for use as a finish coat on all Military tactical equipment, which includes ground and related support assets. The materials are free of Hazardous Air Pollutants (HAPS), lead and chromate free, and have a low Volatile Organic Compounds (VOCs) content.
- b. MIL-DTL-53039: A single component chemical agent resistant, aliphatic polyurethane coating for use as a finish coat on Military combat equipment. The coating is lead hexavalent chromium free and has low Volatile Organic Compounds (VOCs) for Type I and II, and zero volatile Hazardous Air Pollutants (HAPS) for Type II.
- c. MIL-PRF-22750: A two-component epoxy polyamide enamel used only on interior surfaces. This is a high-solids epoxy coating with a low Volatile Organic Compounds (VOCs) content.

Coating, Two-Component Water Dispersible Aliphatic Polyurethane, Chemical Agent Resistant (MIL-DTL-64159)**Characteristics**

This is a water dispersible, hazardous air pollutants (HAP-free), lead and chromate (hexavalent chromium) free, and have a maximum volatile organic compound (VOC) content of 220 g/l (1.8 lb/gal) as packaged.

Use

CARC is intended for use over new or previously painted surfaces. It is applied over pretreated surfaces after priming with an epoxy primer (MIL-DTL-0053022 or MIL-DTL-0053030). CARC can be applied over thoroughly prepared existing CARC surfaces. It cannot be applied over lacquer. MIL-DTL-64159 is for exterior surfaces and interior surfaces routinely exposed to the outside (i.e., door ramps, hatches, etc.).

CHEMICAL AGENT RESISTANT COATINGS (CARC) (continued)**CAUTION**

Components of different colors are not interchangeable. Component A of one color may not be used with Component B of another color. Components from different manufacturers may not be mixed.

CAUTION

Do not use CARC on items which are flexible. Because of its rigidity, the finish may crack when item is bent.

CAUTION

CARC application requires extremely clean surface preparation. Prior to painting, check cleanliness with the red litmus or water break tests.

Application

Pigments of Component A have a tendency to settle and cake due to the solids content. These solids must be dispersed into a smooth, uniform solution prior to addition of catalyst. This can best be accomplished by mechanically agitating or stirring Component A for 30 minutes before mixing. The catalyst, Component B, must be a clear to pale yellow liquid and must be free of crystals. A cloudy, milky, or crystalline gel indicates that catalyst is contaminated and should not be used. If container for Component B is swollen, do not open it. Dispose of it as a hazardous waste. Both components should always be measured because accuracy is very important. Thinning should not be necessary for brush application. For adequate camouflage properties, it is necessary to apply coating to a minimum dry film thickness of .0018 inch (46 microns).

Under certain temperature and humidity conditions, for more even results, it may be advisable to apply two coats of a minimum thickness of .0009 inches (23 microns) each. Component B is water sensitive and caution must be taken to ensure water or high humidity does not come in contact with coating. Mixed coating must be used within eight hours and cannot be stored. Once opened, component B must be used that day or stored in a sealed dry air/airless container.

Drying Time

Curing time increases with lower temperature or higher humidity.

Coating, Aliphatic Polyurethane, Single Component, Chemical Agent Resistant (MIL-DTL-53039)**Characteristics**

It is a lead and chromate free, single component CARC low Volatile Organic Compounds (VOCs) as packaged.

CHEMICAL AGENT RESISTANT COATINGS (CARC) (continued)**CAUTION**

CARC application requires extremely clean surface preparation. Prior to painting, check cleanliness with the red litmus or water break tests.

CAUTION

Never mix components of any specification. They are not compatible.

CAUTION

Do not use CARC on flexible items. Because of CARC's rigidity, doing so may cause cracking of the finish.

Use

CARC is intended for use over new, pretreated surfaces. It is applied over pretreated surfaces after priming with an epoxy primer (MIL-DTL-0053022 or MIL-DTL-0053030). CARC can be applied over thoroughly prepared CARC surfaces. MIL-DTL-53039 is for exterior surfaces and interior surfaces routinely exposed to the outside (i.e. door ramps, hatches, etc.).

Coating, Aliphatic Polyurethane, Single Component, Chemical Agent Resistant (MIL-DTL-53039) (Continued)**CAUTION**

Coating is very water sensitive and caution must be taken to ensure water or high humidity does not come in contact with coating before it is cured.

CAUTION

Spray lines used for epoxy should not be used with polyurethanes without complete flushing or cleaning with solvents.

Application

Thinning should not be necessary for brush application. It can be thinned for spraying by mixing up to one part by volume of applicable solvent with four parts by volume of MIL-DTL-53039. The applicable solvent for all areas is solvent recommended by Manufacturer or aircraft thinner (MIL-T-81772). For adequate camouflage properties, it is necessary to apply coating to a minimum dry film thickness of .0018 inch (.0046 cm). Under certain temperature and humidity conditions, for more even results, it may be advisable to apply two coats of a minimum thickness of .0009 inches (.0023 cm) each. Once opened, MIL-DTL-53039 must be used within eight hours, unless stored under a blanket of moisture free air or dry nitrogen.

Coating, Epoxy Polyamide Enamel, Chemical Agent Resistant (MIL-PRF-22750)**Drying/Curing Time**

Curing time increases with lower temperature or higher humidity. At temperatures of 70°F (21°C) and above, MIL-DTL-53039 will dry within specification requirements (sets to touch in approximately 15 minutes, dries hard in 90 minutes, dries through in four hours, with a complete cure within seven days). At 60°F (16°C), MIL-DTL-53039 requires twice as long to cure.

CAUTION

Neither component of MIL-PRF-22750 is compatible with the single component MIL-DTL-53039, and should never be mixed with it.

Characteristics

This specification is for use on interior surfaces of equipment, vehicles, vans, and shelters. CARC is designed for easy decontamination after liquid chemical agent exposure. Interior surfaces which become exterior surfaces upon opening (ramps, hatches, etc.) should be painted with MIL-DTL-53039.

Use

CARC is intended for use over new or previously painted surfaces. It is applied over pretreated surfaces after priming with an epoxy primer (MIL-DTL-0053022 or MIL-DTL-0053030).

CAUTION

Component B is water sensitive and caution must be taken to ensure water or high humidity does not come in contact with coating before it is cured.

CAUTION

Components of different colors are not interchangeable. Component A of one color may not be used with Component B of another color. Components from different Manufacturers may not be mixed.

CAUTION

Spray lines used for epoxy should not be used with polyurethanes without complete flushing or cleaning with solvents.

CAUTION

CARC application requires extremely clean surfaces. Prior to painting, check cleanliness with a red litmus or water break test.

Application

Pigments of Component A have a tendency to settle. Stirring for 20 minutes is necessary to disperse these solids into a smooth, uniform solution prior to addition of a catalyst. The catalyst, Component B, must be clear. Thickening or gelling with presence of crystals indicates that catalyst is not usable. MIL-PRF-22750 should be mixed in accordance with Manufacturer's instructions. The mixed components shall stand for an induction time specified by Manufacturer before using. This coating can be thinned, if necessary. For adequate resistance properties, coating should be applied to a minimum dry film thickness of .0018 inch (.0048 cm). Mixed coating must be used within pot life specified by Manufacturer, and cannot be stored.

Drying Time

At 70°F (21°C) and above, MIL-PRF-22750 will dry within specification requirements (sets to touch in approximately 20 minutes, dries hard in 90 minutes, dries through in four hours, with a complete cure within seven days).

CARC Shelf Life Extension

To determine if shelf life of CARC can be extended, perform following inspections:

Condition in container: Should be no excessive skinning, hard settling or resin separation.

Viscosity: Should be no excessive increase in viscosity from specification requirements.

Drying time: Should conform to specification.

Application: Should conform to specification label instructions.

Thinning: Should thin adequately with designated thinners.

Gloss: Should conform to specification requirements.

Color: Should conform to specification requirements.

If paint meets criteria of inspection items above, shelf life may be extended by 50%. For example, a paint with a shelf life of one year could be extended six months if it passes inspection above.

For further information about CARC paint inspection, testing and shelf life extension, write to: CARC Commodity Manager, US Army Research Laboratory, 4600 Deer Creek Loop, AMSRD-ARL-WM-MC, Aberdeen Proving Ground, MD 21005-5069.

Coating Compound, Nonslip (For Walkways) (A-A-59166)

Enamels are pigmented finishing materials that, in general, dry to a hard gloss, semi gloss, or lusterless finish. The nonvolatile vehicles in enamels may be oils, natural or synthetic resins, soluble cottons, or their combinations.

Characteristics

This enamel provides a very coarse, gritty coating, similar to coarse sandpaper. It is to be applied over any previously painted or primed surface, including surfaces previously painted with CARC, alkyd, or enamel.

Use

A heavy coating is to be applied on surfaces that might become wet in order to provide a more secure footing. For painting tank turret floors, a heavy coating of white enamel is to be used.

Application

When brushing, apply as issued or thin to not more than 5 % by volume. If enamel is to be sprayed, thin to 15 % by volume. Use thinner specified by Manufacturer. The enamel can also be trowelled on; apply as issued. The thickness of coating should be from 1/32 to 1/16 of an inch to ensure retention, with maximum durability, and nonskid properties. For tactical equipment, apply compound over CARC primer, and apply CARC topcoat over compound; for nontactical equipment, do not apply CARC topcoat over compound.

PAINTS**Paint, Heat-Resisting (For Steel Surfaces) (MIL-P-14105)****Characteristics**

This paint contains a blend of ceramic frits, refractories, and pigments in a vehicle of pure or modified silicone resins.

Use

This paint is intended for use on solvent degreased and blasted steel surfaces of components which are subject to temperatures as high as 1400°F (760°C) and exterior weathering. Components such as mufflers, manifolds, and stacks may be protected by use of this paint. The paint provides excellent protection against corrosion and chemical attack. It has also been found to perform satisfactorily when applied to parts that do not lend themselves to sand blasting. In application to such parts, however, it is absolutely necessary that all loose rust and tight and loose mill scale be removed by wire brushing and chipping. Coatings should then be applied by brushing, taking care to work the paint well into the roughened surfaces.

Application

Apply by brushing as received, or by spraying reduced in accordance with Manufacturer's recommendations.

Drying Time

Paint air dries tack-free within one hour. Dries hard when baked at 400°F (204°C) for 30 minutes.

TOUCHUP AND RECOATING**WARNING**

CARC topcoat paint contains isocyanides (ICN), which can trigger an allergic reaction in some people (lasting a few days to a few months) producing asthmatic like symptoms such as coughing, wheezing, tightness in the chest, shortness of breath, including reddening of the skin and eyes, and itching. If you are or become sensitized to CARC paint never use or apply CARC paint even if the above symptoms are minor. Observe the following precautions to ensure the safety of personnel when CARC paint is applied:

Camouflage CARC coatings can be applied on; MIL-DTL-0053022, Primer, Epoxy Coating, Corrosion Inhibiting, Lead and Chromate Free; MIL-DTL-0053030, Primer Coating, Epoxy, Water Reducible, Lead and Chromate Free; MIL-DTL-64159, Coating, Water Dispersible Aliphatic Polyurethane; MIL-DTL 53039, Coating, Aliphatic Polyurethane, Single Component, Chemical Agent Resistant; MIL-PRF-22750, Coating, Epoxy, High Solids, and fully cured alkyd surfaces. All of these surfaces must be clean and free of all contaminants such as oil, grease, fuel, hydraulic/transmission fluid, wax, carbon deposits, sanding debris, water, and fingerprints. Clean surfaces should be tested using a red litmus or water break tests. CARC cannot be applied over lacquer. All lacquer painted items must be stripped down to the epoxy prior to application of CARC.

TOUCHUP AND RECOATING (continued)

WARNING

Avoid breathing vapors from cleaners. Do not use cleaners in poorly ventilated areas. Doing so may result in death or injury to personnel.

The primary method for determining whether equipment is currently painted with CARC or alkyd is to examine the area near the equipment data plate. The word "CARC" or "ALKYD" should be stenciled nearby. For equipment without a data plate, thoroughly wet a rag with Acetone, ASTM D329, and briskly rub the painted surface for twenty (20) seconds. Evidence of actual paint removal onto rag indicates an alkyd painted surface.

ENGINE, ENGINE ACCESSORIES, ENGINE COMPARTMENTS (if applicable)**CAUTION**

Mask intake and exhaust ports, breathers, etc., carefully to prevent dust, solution, water, or metal conditioner from entering engine.

Chemical Agent Resistant Coating (CARC) should be used on all surfaces, interior and exterior, of tactical (combat, combat support and ground support) equipment where temperature does not exceed 400°F. This would include engine compartments, for example. The type and color for interior should be specified to facilitate maintenance or human factors engineering considerations.

Engines, engine components, and powertrain assemblies which are normally painted should be painted consistent with above paragraph. For areas that exceed 400°F, paint should conform to MIL-P-14105, Paint, Heat Resisting (for Steel Surfaces) as applicable. Generally, this means that exposed engines (e.g., on a road grader) or engine components should be painted with MIL-P-14105 in a camouflage pattern compatible color. While intended use of MIL-P-14105 is on ferrous substrates, it will work on aluminum, but performance limit of coating (1400°F, 760°C) is well above melting point of aluminum. Coating should not be used with a primer.

Engine Compartments: All exterior surfaces of combat vehicle engine compartments not exposed to outside view shall be painted white or light green for better reflection of light.

END OF WORK PACKAGE

CHAPTER 4
CAMOUFLAGING PROCEDURES
FOR
PAINTING INSTRUCTIONS FOR
ARMY MATERIEL

CAMOUFLAGING PATTERN PAINTING

SCOPE

This chapter covers methods of applying Camouflage Paint Patterns (CPPs) to Army materiel. It also covers procedures for inspecting applied CPP. Equipment consists mainly of brushes, rollers and spray guns; finish systems consist of Chemical Agent Resistant Coatings (CARC). The CARC topcoats are suited for camouflage painting and protect Military materiel against visual and infrared detection and chemical agent contamination. The CARC camouflage topcoats are MIL-DTL-64159, Coating, Water Dispersible Aliphatic Polyurethane, Chemical Agent Resistant, and MIL-DTL-53039, Coating, Aliphatic Polyurethane, Single Component, Chemical Agent Resistant. CARC epoxy primers are MIL-DTL-0053022, Primer, Epoxy Coating, Corrosion Inhibiting, Lead and Chromate Free, and MIL-DTL-0053030 Primer Coating, Epoxy, Water Reducible, Lead and Chromate Free. WP0021 00, of this Technical Manual (TM) contains tables with National Stock Numbers (NSNs) for these materials.

Information on specific finish systems and kinds of paint to be used for various applications is contained in Chapter 3, of this TM. Surface preparation is also covered in Chapter 3. Application techniques and equipment are covered in Chapter 5, of this TM. For additional information on camouflage, refer to AR 750-1 Army Materiel Maintenance Policy.

Major items to be camouflage painted are weapons systems, vehicles, communications equipment, construction equipment, and materials handling equipment. Three-color camouflage patterns are created for all combat, combat support, and combat service support equipment having an area greater than nine square feet on one or more sides. New items of Tactical Equipment normally will be CARC coated in a three-color camouflage pattern at the factory or Sustainment Level Maintenance. Some items, however, may be painted with lusterless CARC green 383(34094), when the pattern has not been developed. These items may be three-color camouflage patterned, at the Commanding Officer's discretion, any time after CPP design development.

Only Field Level Maintenance and Sustainment Level Maintenance personnel with equipment and paint booths meeting Occupational Safety and Health Administration (OSHA) standards are authorized complete painting and/or repainting of equipment or components; if such equipment/booths are not available, only touch-up efforts are authorized.

REASON FOR PATTERN PAINTING

All Military vehicles and equipment have characteristic shapes and shadows. These shapes and shadows contrast with material surroundings and make object stand out. Pattern painting using wavy, irregular patches of camouflage colors does much to break up characteristic shapes of equipment by reducing contrasts with soil and vegetation, pattern shape, and placement. Patterns have been designed for each type of vehicle to cut off sharp corners, avoid straight, vertical, and horizontal lines, and extend shadows in shapes similar to natural features and vegetation; however, accuracy with which Camouflage Paint Patterns (CPPs) is applied completely determines how well CPP camouflages equipment.

REASON FOR PATTERN PAINTING (continued)

Pattern painting is not a magic, cure-all camouflage technique, but it makes an item much harder to see and recognize as a military object. It also provides an excellent base for applying further natural camouflage such as tree limbs, shrubs, and grass

NOTE

Mixing Chemical Agent Resistant Coating (CARC) colors with one another will alter their individual effectiveness when applied to end item. Blending, therefore, is not permitted.

Camouflage finishes better lend themselves to touchup painting than do current olive-drab coatings. Slight mismatches in color are expected at times and will not be noticeable except upon close inspection. Likewise, minor abrasions and scaling of surfaces will be equally inconspicuous. Marring and surface lightening due to handling is characteristic of camouflage coatings and does not impede camouflage or infrared properties. This is typical of low gloss and sheen coatings in dark colors and is considered satisfactory.

PATTERN DESIGNS

WARNING

The local Safety Office and Industrial Hygienist must be consulted before beginning/changing any painting operation. Failure to do so may result in death or injury to personnel.

Before applying Camouflage Paint Patterns (CPPs) to equipment, pattern design for that equipment must be obtained.

Each type of item has its own CPP design which consists of five views of the equipment: Front, Back Left side, Right side and Top. Also issued with designs are inspection worksheets and overspray gages, which are necessary for inspecting CPP once it is applied. To obtain design, inspection worksheets, and/or overspray gages, write to:

US Army
CERDEC NVESD
Science & Technology Div
10221 Burbeck
Ft Belvoir, VA 22060-5806

PATTERN DESIGNS (continued)

For equipment being camouflaged, furnish the following data with your request:

- National Stock Number (NSN)
- Nomenclature
- Model Number (where applicable)
- Standard Study Number (if known)
- Line Item Number (if known)

Refer to Figure 11-1, for an example of Camouflage Paint Patterns (CPPs) for the M1025 Utility Truck. Within each area is a number that stands for color to be painted. The base or primary color is designated #2. Color #2 is usually applied first over all surfaces. Color patches #1 and #3 are then applied over primary coating.

CHOICE OF METHOD

There are four CPP application methods: Robotic, Template, Projection and Manual. Robotic application is the most accurate and consistent, and where a number of like items must be camouflaged, this method merits serious consideration. Template application is the next most accurate and repeatable method, and where the robotic method is deemed impractical, the template method should then be considered. The projection method is less accurate and repeatable. However, where a limited number of like items are to be camouflaged, it may be more practical/cost-effective than the robotic and template methods. Manual application is the least accurate, least repeatable method, and for this reason its use is greatly discouraged. It should be used only when the other three methods, for whatever reason, have been ruled out.

ROBOTIC METHOD

The robotic method of applying patterns uses an automated robotic program to establish the color boundary lines simultaneously as the paint is applied to the bands and patches. Each color is automatically applied to its respective color area by robotics preprogrammed to apply the designated pattern. No human participation is required.

Degree of Accuracy/Consistency

It is considered to be the most accurate and repeatable method of CPP application.

Inspection Requirements

The first pattern applied by a robotic program should be fully inspected. However, once that pattern passes inspection, that robotic painting program is "certified". Subsequent patterns applied using certified programs need be inspected only on a random sample basis. Refer to WP0012 00, Inspection Procedures, of this Technical Manual (TM).

TEMPLATE METHOD

The template method of pattern application uses either rigid or soft templates to locate and mark pattern color boundary lines on an item that requires a CPP. Templates are fabricated from rigid material (wood, aluminum, etc.) or soft, flexible material (Mylar, plastic sheets, etc.). The fabricated template is precisely positioned on surface to be patterned, which must already be completely coated with base color (#2 on CPP design). The boundaries are then located and drawn with soapstone or chalk onto surface. Finally, painter fills in color areas #1 and #3 of CPP with colors designated on design.

Degree of Accuracy/Consistency

After the robotic method, it is the next most accurate and repeatable.

Inspection Requirements

The first pattern applied using a template must be fully inspected in accordance with WP000 12, Inspection Procedures. However, once that pattern passes inspection, the template is "certified". Subsequent patterns applied with this template need be inspected only on a random sample basis.

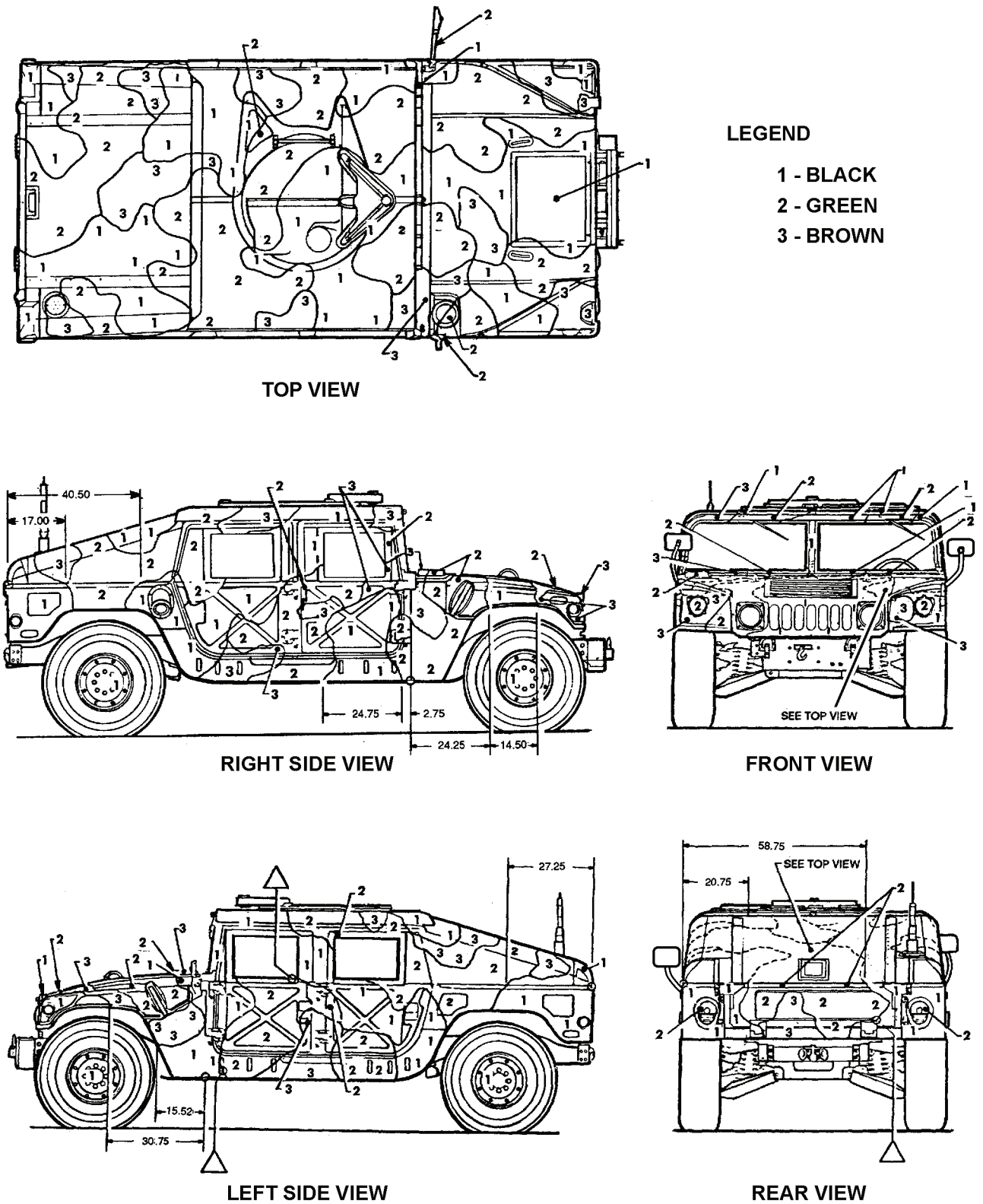

TB430139-001

Figure 11-1. Pattern Painting Design for the M1025 Utility Truck

PROJECTION METHOD

The projection method utilizes transparent reductions of Camouflage Pattern Painting (CPPs) drawings which are transferred directly onto item by illuminated projection. This method permits color boundary lines to be traced manually using chalk or soapstone.

Degree of Accuracy/Consistency

It is an inaccurate, inconsistent method of CPP application, but it is slightly more desirable than manual pattern application method. Its use, however, may be necessitated by practicality and cost effectiveness constraints, especially when there are only a small or limited number of the same item requiring CPP application (i.e. when cost tradeoff may not justify development of soft or hard templates or robotic programs).

Inspection Requirements

Every pattern applied using projection method must be fully inspected in accordance with WP0012 00, Inspection Procedures, of this Technical Manual (TM). No random sampling is permitted.

MANUAL METHOD

Manual application of color boundary lines is considered to be the least accurate and least repeatable method of CPP application. This method uses a modified "free-hand" approach for applying color boundaries with the aid of various pattern point guideline methods such as grid layout, transfer of scaled points from CPP drawings, etc.

Degree of Accuracy/Consistency

The manual method is the least accurate, least repeatable application method. Therefore, its use is greatly discouraged. It is considered a last resort' method.

Inspection Requirements

Every pattern applied using the manual method must be fully inspected in accordance with WP0012 00, Inspection Procedures. No random sampling is permitted.

MARKINGS ON CAMOUFLAGED EQUIPMENT

After equipment has been pattern painted, only the following markings are to be applied:

NOTE

Markings on Chemical Agent Resistant Coating (CARC) camouflaged equipment will be CARC in colors designated in Figure 11-2.

- Unit Identification. Type and location remain the same.

MARKINGS ON CAMOUFLAGED EQUIPMENT (continued)

- **National Symbol.** Paint a three inch star on both front and rear. Symbol should be centered on the equipment, on line with unit ID markings. On rear of wheeled vehicles, star may be placed on tailgate.
- **Agency Identification and Registration Number.** The identification and registration number shall be placed on any appropriate interior area, if available, which is visible from outside a locked or secured item.
- **Safety and Instructional Markings.** Markings such as tire pressure, fuel type, and fill level will be in letters no larger than one inch. Markings directly related to troop safety, such as wrecker boom capacity and danger zones, must be evaluated by Safety Personnel.
- **CARC Markings.** Equipment with data plates shall have the word "CARC" painted in a conspicuous area as near the data plate as possible. Painting shall be in block letters, as large as possible, not to exceed one inch. All major items having a log book shall have the Equipment Control Record, DA Form 2408-9, (Figure 11-3) annotated in the lower left corner of block 21, Remarks, reflecting the word "CARC", and the date applied.

MARKINGS ON CAMOUFLAGED EQUIPMENT (continued)

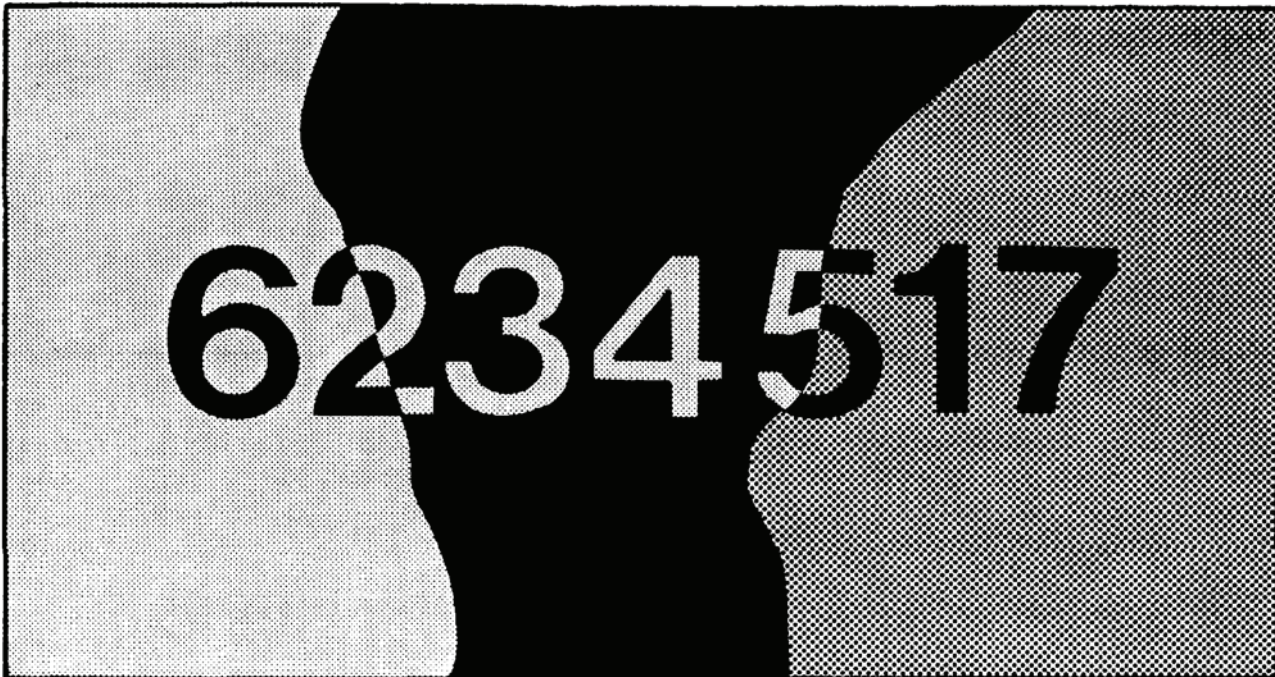

BACKGROUND COLOR AREA

BROWN 383, 30051
 GREEN 383, 34094
 BLACK 37030 or 37038
 TAN 686

LUSTERLESS LETTER COLOR

BLACK 37030 or 37038
 BLACK 37030 or 37038
 GREEN 383, 34094
 BROWN 383, 30051

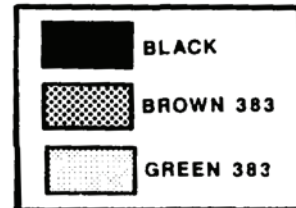

Figure 11-2. Markings On Camouflage Equipment.

TB430139-002

MARKINGS ON CAMOUFLAGGED EQUIPMENT (continued)

CONTROL NO.	1. ORGANIZATION	2. LOCATION	3. UNIT IDENT CODE	4. UTILIZATION CODE	5. VEHICLE USE CODE
6. NOMENCLATURE	7. MODEL	8. NATIONAL STOCK NO.	9. SERIAL NO.	10. REGISTRATION NO	
11. YEAR OF MFG	12. MANUFACTURER (MFG Code)	13. CONTRACT NO.	14. PURCHASE ORDER NO.		15. WARRANTY PERIOD
16. TYPE REPORT	17. REPORT CODE	18. USAGE	19. SHIPPED TO a. ORGANIZATION		b. SHIPPED TO UIC
a. ACCEPTANCE AND REGISTRATION		a. HOURS	20. RECEIVED FROM a. ORGANIZATION		b. RECEIVED FROM UIC
b. USAGE		b. MILES			
c. TRANSFER		c. ROUNDS			
d. LOSS					
e. GAIN					
f. OTHER					
21. REMARKS					
22. INSPECTOR'S SIGNATURE				23. JULIAN DATE	
EQUIPMENT CONTROL RECORD				<i>REPORTS CONTROL SYMBOL</i>	
<small>For use of this form, see DA Pam 738-750; the proponent agency is DCSLOG</small>				<i>CSGLD- 1608</i>	

DA FORM 2408-9, 1 OCT 1972

REPLACES DA FORMS 2408-7, 1 JAN 1964, AND 2408-8, 1 JAN 1964, WHICH ARE OBSOLETE

USAPA V1.00

NMP COPY 1 CONTROL COPY 2 LOG BOOK COPY 3

Figure 11-3. Equipment Control Record, DA Form 2408-9.

END OF WORK PACKAGE

0011 00-9/ (10 blank)

INSPECTION PROCEDURES

SCOPE

This Work Package (WP) provides an overview of the three levels of inspection that are required.

GENERAL

The full Camouflage Paint Patterns (CPP) inspection consists of three levels of inspection: Level I, Level II, and Level III. Level I is essentially a visual conformance check from 50 feet or more. Level II is a close-up boundary inspection using a CPP overspray gage. Level III is a detailed comparison of actual physical measurements to nominal dimensions.

MATERIALS/TOOLS REQUIRED

After becoming completely familiar with inspection procedures outlined below, the inspector should assemble the following materials/tools:

- CPP designs, including inspection worksheet and overspray gage as shown in Figure 12-1
- One (1) 6-foot steel measuring tape, graduated in sixteenths (or thirty-seconds) of an inch
- One (1) 6-foot steel measuring tape, graduated in tenths of an inch
- Small T-square and/or straight edge
- Soapstone or chalk
- Pen, pencils, colored pencils
- Paper/notebook
- One plumb bob, with string

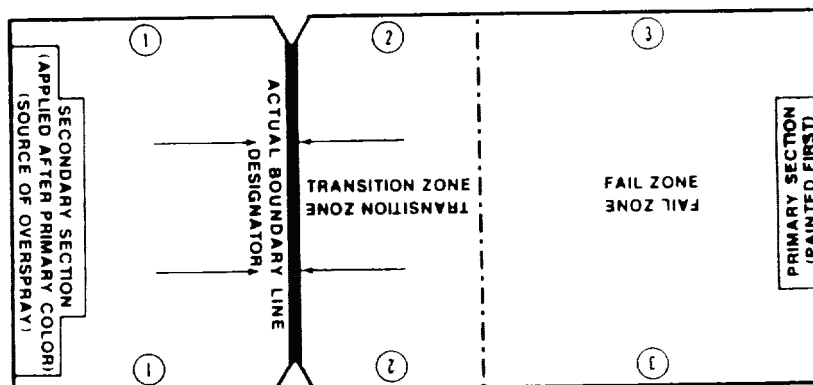

Figure 12-1. Overspray Gage

LEVEL I INSPECTION

In this level of inspection, the inspector, from a distance of 50 feet or more from item, visually compares colors, shapes and boundaries of applied pattern to those of the design pattern, by using the following sequence of steps:

1. Ensure data on identification plate of item to be inspected corresponds to data on Camouflage Paint Patterns (CPP) drawings. If not, the CPP inspection cannot be performed until the correct drawing set is obtained, as specified in WP 0011 00, Camouflage Pattern Painting, of this Technical Manual (TM).
2. With 2 different colored pencils, shade color areas #1 and #3 of drawing set, including inspection worksheet.
3. Begin with right side view. If from that view, items are 20 feet or less long, stand 50 feet from it. If item is over 20 feet but less than 40 feet in length, stand 75 feet from it. If item is longer than 40 feet stand 100 feet from it.
4. Compare right side as drawn with actual right side view of item:
 - a. Ensure all black disruptive bands have been properly located on item.
 - b. Verify comparative size and direction of black bands with those on drawing.
 - c. Ensure black boundary lines closely conform to shape of boundaries depicted on CPP drawings.
 - d. Ensure all brown patches have been properly located on item.
 - e. Ensure contours are sharply defined, and shapes of brown patches closely conform with those on CPP drawings.

5. Document any failures (differences found between applied pattern and drawing pattern) as follows:
 - a. Mark failed area on item with chalk or soapstone.
 - b. Record failure on inspection worksheet.
 - c. Describe failure in notebook for painter/contractor debriefing.
 - d. Report failure in specific detail to painter/contractor to facilitate correction. Reference points may be used to show failure location.
 - e. Provide constructive guidance on corrective action (e.g., inspector may even draw correct contour line on item and direct repainting within this line.
6. Repeat steps 3 thru 5 for other four drawing views. Level I inspection is complete when each view is examined in this manner, and when all corrections have been witnessed and accepted by Inspector.

LEVEL II INSPECTION

In this level of inspection, borders are examined to ensure color definition. Contrast between color areas is key to CPP effectiveness, and, for this reason, overspray of one color into another color area must be minimized to a 1-1/2 inch tolerance. An overspray gage, as shown in Figure 12-1, is used to determine whether overspray on applied Camouflage Paint Patterns (CPP) is within this narrow tolerance.

Overspray

Unless applied robotically, pattern colors are applied in sequence, beginning with a base coat in primary color (#2 on CPP drawings). The other two color patches/bands are spray-painted, one after another, over this base coat. A normal result of this process is overspray, overlapping mist of one paint color on an adjacent color area which impairs CPP effectiveness. With experience, painters can minimize overspray.

Overspray Gage

The overspray gage shown in Figure 12-1 is a card-like, transparent sheet of plastic with white markings (to contrast with camouflage colors) which indicate the tolerance, or "transition" zone. This gage is overlaid on border area; the actual border line is then located and aligned under gage boundary line "DESIGNATOR", and overspray is examined. When overspray extends into "FAIL ZONE", failure location is noted by marking notches at both ends of gage boundary line DESIGNATOR with chalk or soapstone.

Areas to be Inspected

Level I inspection included a visual check from a distance of contour definition. Any areas noted where contours were NOT sharply defined should be inspected for overspray failure. Special attention should be given to black disruptive bands, which are especially important to CPP effectiveness.

Level II Inspection Procedure

For each area noted in Areas to be inspected above, complete following steps:

1. Lay overspray gage over border, so that FAIL ZONE lays over color area applied first.
2. Align DESIGNATOR, or boundary line marking, as close as possible to fog/boundary transition area, so that it is just short of overlapping spray, but so that no primary color can be seen in secondary section.
3. Examine overspray. If it extends into FAIL ZONE, record Level II failure as follows:
 - (a) Mark notches at both ends of DESIGNATOR line on gage with chalk or soapstone.
 - (b) Record overspray failure on inspection worksheet.
 - (c) Make descriptive entry in notebook for painter/contractor debriefing.
 - (d) Report overspray failure in specific detail to painter/contractor. Show failure location.
 - (e) Provide constructive guidance on corrective action.
 - (f) Level II Inspection Completion. This level of CPP inspection is complete when each view of item is inspected in this manner, and when inspector has witnessed and accepted all corrections.

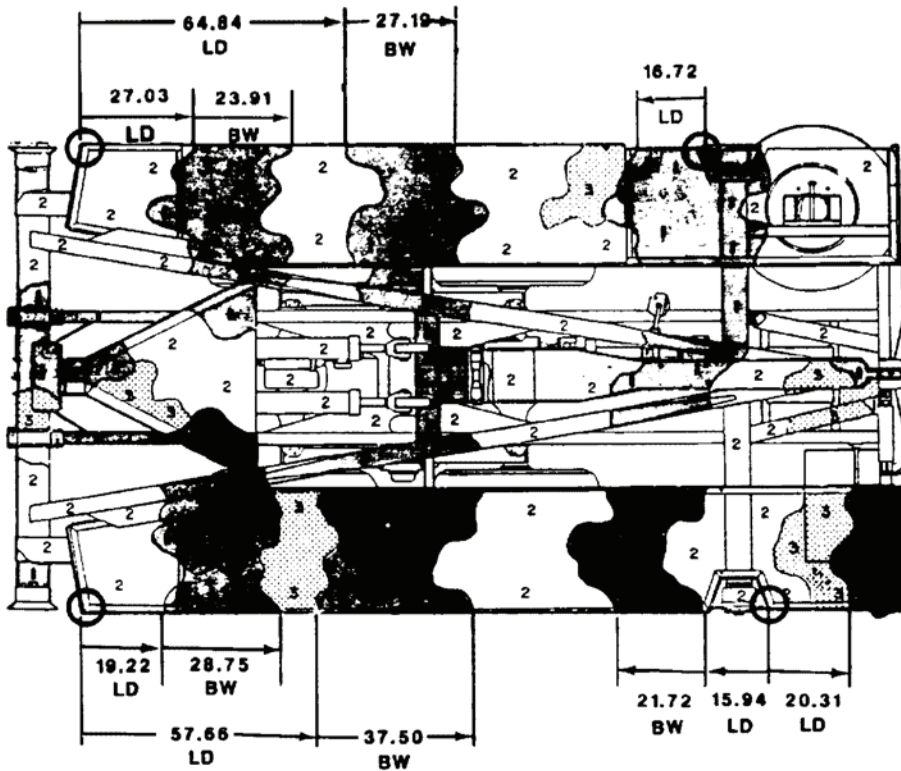
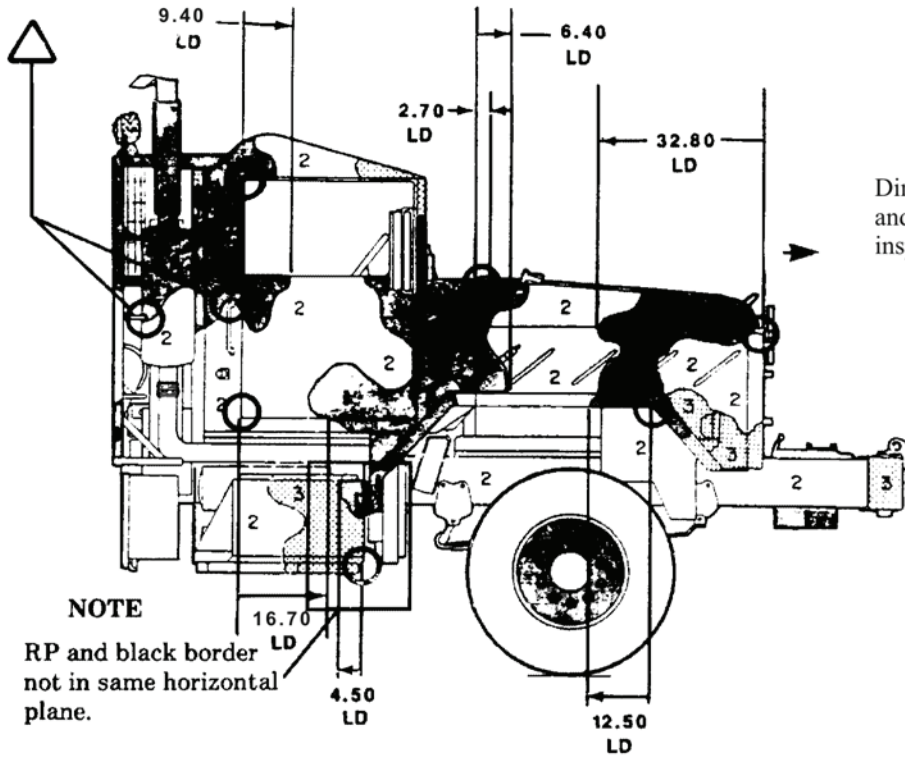

Figure 12-2. Typical Views On Inspection Worksheet

TM430139-003

LEVEL III INSPECTION

This level of inspection entails contrasting actual versus nominal dimensions of Camouflage Paint Patterns (CPP). Specifically, the inspector verifies that all black disruptive bands were applied within plus (+) 1 inch of location specified on worksheet. Reference points are used to make these measurements. At least one point on each boundary of black bands must be measured from a nearby reference point. Inspections, however, are not limited to one point per border, or to reference points indicated on worksheet.

Reference Points (RPs)

RPs are denoted on inspection worksheets as shown in Figure 12-2, by small circles (o). They are usually (not always) located at the intersection of two physical line features, such as the corner of a door.

Deltas

Deltas are denoted by triangles (Δ) on inspection worksheets, as shown in Figure 12-2. They are reference points which are located within an inch radius of a black band border.

Locating Dimensions (LDs)

The LD is the horizontal distance between a reference point and a black band border. The LD must be within plus (+) 1 inch of dimension specified on inspection worksheet, as shown in Figure 12-2.

Bandwidths (BWs)

The BW is distance between a point on one border of a black band and a point on a different border of same band. Like LDs, actual BWs must be within plus (+) 1 inch of those specified on inspection worksheet.

Level III Inspection Procedure

The simplest way to inspect CPPs at this level is to check each delta, LD and BW indicated on worksheet.

1. Deltas. A delta on worksheet, as shown in Figure 12-2, is indicated by a small triangle. Check these as follows:
 - a. Locate delta on worksheet. Some physical equipment feature, such as the top of a door handle or a panel corner, should intersect a black band border within ± 1 inch.
 - b. Go to equipment being inspected, and locate this feature.
 - c. On applied CPP, locate corresponding black band border, and using overspray gage, find actual border line, marking notches with chalk or soapstone.
 - d. Use a ruler to determine whether any point on actual border line is within a one inch radius of actual physical feature.

LEVEL III INSPECTION (continued)

- e. If no point on border line is within this radius, a level III failure must be documented. As with level II failures, failure location on applied CPP should be marked with chalk or soapstone, and failure should also be recorded on worksheet. A notebook entry and detailed report to painter, as with level II failures, should also be made. The inspector must guide, witness and accept corrections of failures.
2. LDs. An LD on inspection worksheet, Figure 12-2, is a dimension (in inches) with arrows and lines from an RP, denoted by a small circle, to a point on a black band border. Check LDs as follows:
 - a. Locate LD on worksheet. Note RP and point on black band border.
 - b. Go to equipment, and locate equipment feature which corresponds to RP on worksheet.
 - c. On applied CPP, locate corresponding black band border.
 - d. If border is at some point straight across from (on same horizontal plane as) RP, use overspray gage to locate actual border line where border intersects RP's horizontal plane.
 - e. Mark point on border line where it intersects this plane, and measure distance from this point to RP.
 - f. If border is not on same horizontal plane as RP, as seen in Figure 12-2 for example, drop a plumb bob from the higher point, and measure distance from lower point to that point where its horizontal plane intersects plumb line. (Again, the overspray gage can help distinguish actual border line).

CAUTION

Vehicle must be on level ground to obtain an accurate measurement.

- g. This distance must be within plus (+) 1 inch of LD on worksheet. If it is not, document a Level III inspection failure in same way as Level II failures.
3. BWs. A BW on inspection worksheet, as seen in Figure 12-2, is a dimension (in inches) with arrows and lines from a point on a black band border to a point on an opposite border of same black band. Check these as follows:
 - a. Locate BW on worksheet. Note points on opposite borders of same black band.
 - b. Go to equipment and locate corresponding points on actual applied borders.
 - c. Use overspray gage to distinguish each actual border line.
 - d. Measure distance between these lines at points corresponding to those marked on worksheet.

- e. If this distance is not within plus (+) 1 inch, document Level III failure in same way as Level II failures.
- f. Level III Inspection Completion. This level of CPP inspection is complete when at least one point on each black band border in each view of the equipment has been checked to ensure its location is within ± 1 inch of that specified on drawings. Checking each LD, delta and BW on inspection worksheet minimally fulfills this requirement; however, additional measurements may be made to increase confidence levels at discretion of Inspector. Inspector must witness and accept correction of all failures found.

COMPLETION OF FULL CAMOUFLAGE PAINT PATTERN (CPP) INSPECTION

The CPP inspection is complete when all three levels of inspection are complete.

SUMMARY OF CPP INSPECTION REQUIREMENTS

Inspection requirements vary with method of CPP application. Robotic and template methods require first applied pattern to pass inspection (all levels), thereby making that robotic program or template certified. Subsequent patterns applied using that program or template shall be inspected on a random sample basis. Manual and projection methods require each and every applied pattern to be inspected (all levels).

TAPE TEST (PAINT ADHESION TEST) FOR ALL FINISHES

Test paint adhesion on coated surfaces: Do not use test panels instead of actual production units. Test surface after paint finish has cured on an out of the way place acceptable to Quality Assurance representatives as follows:

- Make a V-shaped scratch through paint finish with a sharp metal blade. Make scratch approximately two (2) inches long and one half (1/2) inch between edges at widest point.
- Press a piece of pressure sensitive tape (3M code no. 250 or equivalent) firmly over the V, in direction indicated on Figure 12-3. Press out air pockets.
- Wait at least ten seconds, and then quickly pull tape away, in direction indicated in Figure 12-3.

Interpret test results as follows:

- If no paint comes off of taped area, coating is acceptable. (Removal of overspray is not a test failure.)
- If topcoat, primer or pretreatment comes off with tape, then coating has failed test and must be removed and another coating applied and tested.
- After test is passed, repair scratched area by feathering-in with appropriate pretreatment, primer and topcoat.

TAPE TEST (PAINT ADHESION TEST) FOR ALL FINISHES (continued)

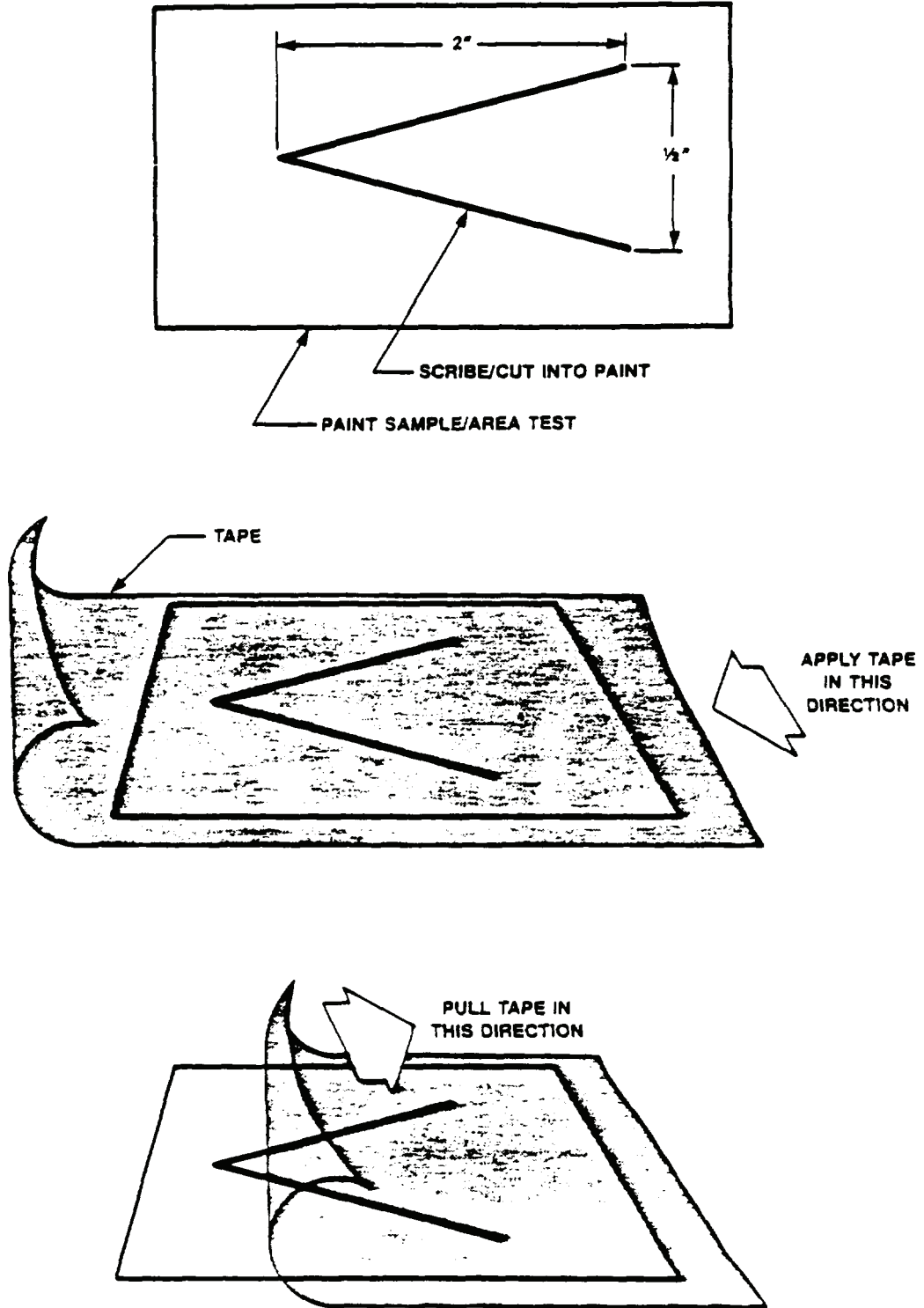

Figure 12-3. Tape Test

END OF WORK PACKAGE

CHAPTER 5
APPLICATION TECHNIQUES AND EQUIPMENT
FOR
PAINTING INSTRUCTIONS FOR
ARMY MATERIEL

SPRAY GUNS AND PRESSURE CANS

SCOPE

This chapter covers techniques and equipment required for application of paint to Army materiel.

SPRAY GUN APPLICATION

Spray gun equipment can be used for any type of finish and on any surface. It does not replace brushes for certain operations, yet there are definite types of work it can do more easily and better than the brush. The spray gun is obviously a tremendous time-saver and its use is recommended when a large volume of work is encountered. The spray gun is particularly adaptable to touchup and maintenance work when the ability to blend old and new surfaces is important. Spray application of any finish type requires respiratory equipment.

Proper operation of spray guns and auxiliary equipment is not difficult to learn, but necessity exists for training operators. Only through such training can full flexibility and operation of spray guns be realized.

SELECTION OF HIGH VOLUME LOW PRESSURE (HVLP) SPRAY GUNS

A paint spray gun as shown in Figure 13-1, is a mechanical means of bringing compressed air and paint together, atomizing or breaking up paint stream into a spray, and ejecting it for the purpose of applying a coating.

There are two types of spray guns. Attached containers and separate containers. These types can be further subdivided into bleeder and non bleeder, external and internal mix, and suction and pressure feed types. The commercially available pressure cans belong to the attached container type. They have a limited use for touchup where compressed air is inaccessible to the job. Airless, portable spray equipment that requires an electric connection also belongs to this type.

Bleeder and Non-bleeder Guns

A bleeder-type gun is characterized by an intentional continuous leakage of air from some part of the gun. This prevents building up air pressure within the hose and permits its use with small compressing systems that are not equipped with an automatic pressure-controlling device. The trigger in a bleeder-type gun controls only the flow of fluid.

A non-bleeder-type gun is one in which the trigger controls passage of both air and fluid. Some type of pressure-controlling device must be used with it.

External and Internal Mix

An external-mix gun is one which mixes air and fluid outside the air cap.

An internal-mix gun mixes air and fluid within the air cap.

NOTE

The term internal mix applies to the air cap alone.

**SELECTION OF HIGH VOLUME LOW PRESSURE (HVLP) SPRAY GUNS
(continued)****Suction and Pressure Feed**

A suction-feed gun is designed to feed the fluid into the air stream through a vacuum created by raising the fluid tip above the air cap. Generally, guns of this type are used with quart-size or smaller containers. A pressure-feed type gun feeds fluid into the air stream (air cap and fluid tip are flush); by means of applied air pressure that forces fluid from the container to the gun.

Airless Spray Equipment

Airless spray equipment uses an electrically operated vibration element which forces the paint up through a tube from the bottom of the container to a nozzle in the cover. This type can be recharged with paint. Refer to Manufacturer's instructions for type of current and voltage required.

SELECTION OF HIGH VOLUME LOW PRESSURE (HVLP) SPRAY GUNS
(continued)

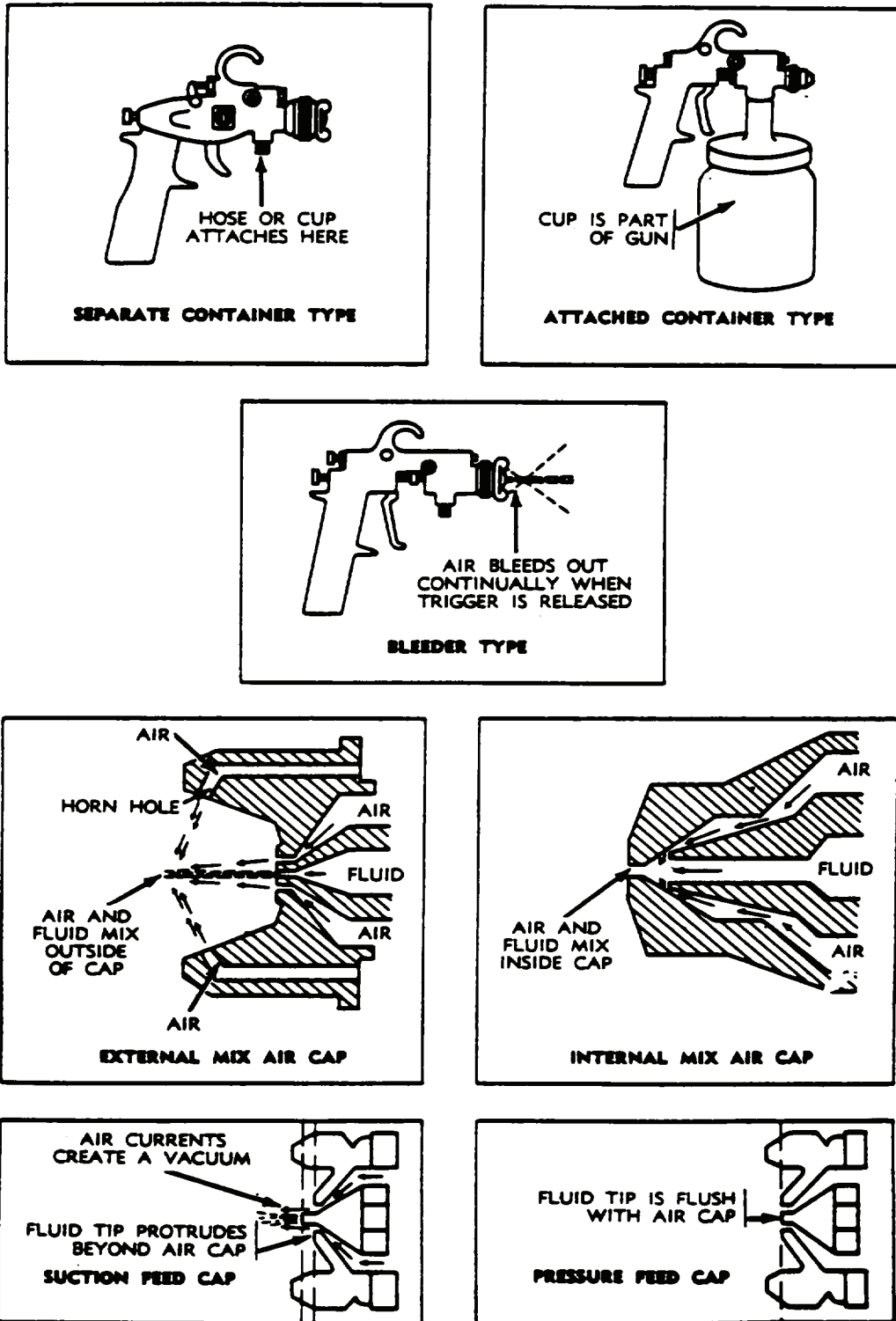

Figure 13-1. Spray Gun Types

SELECTION OF AIR CAPS, NEEDLES, AND NOZZLES

The performance of an air gun with any kind of material depends primarily on the selection of the proper air cap, fluid needle, and fluid tip (or nozzle). Manufacturers identify combinations of these parts intended to be used together, and their recommendations should be followed in respect to the proper combination for a particular material. Occasionally, changing the type of feed will necessitate a different combination of air cap, fluid tip, and fluid needle.

SPRAY GUN TECHNIQUES**WARNING**

All personnel who work in a spray painting booth must wear a National Institute for Occupational Safety and Health (NIOSH) approved respirator as well as Personal Protective Equipment (PPE), when spray painting operations are underway. Failure to do so may cause death or injury to personnel.

WARNING

Spray painting will be done only in areas designated for that use. All personnel within a paint booth must be equally protected with proper Personal Protective Equipment (PPE). No unprotected personnel may enter a paint booth without protection until 30 minutes after all painting/cleaning is completed. Failure to do so may cause death or injury to personnel.

WARNING

Only one person will spray paint on an item at a time, unless all people are protected. This is to eliminate the hazard of accidentally spraying paint on another person. Failure to do so may cause death or injury to personnel.

SPRAY GUN TECHNIQUES (continued)

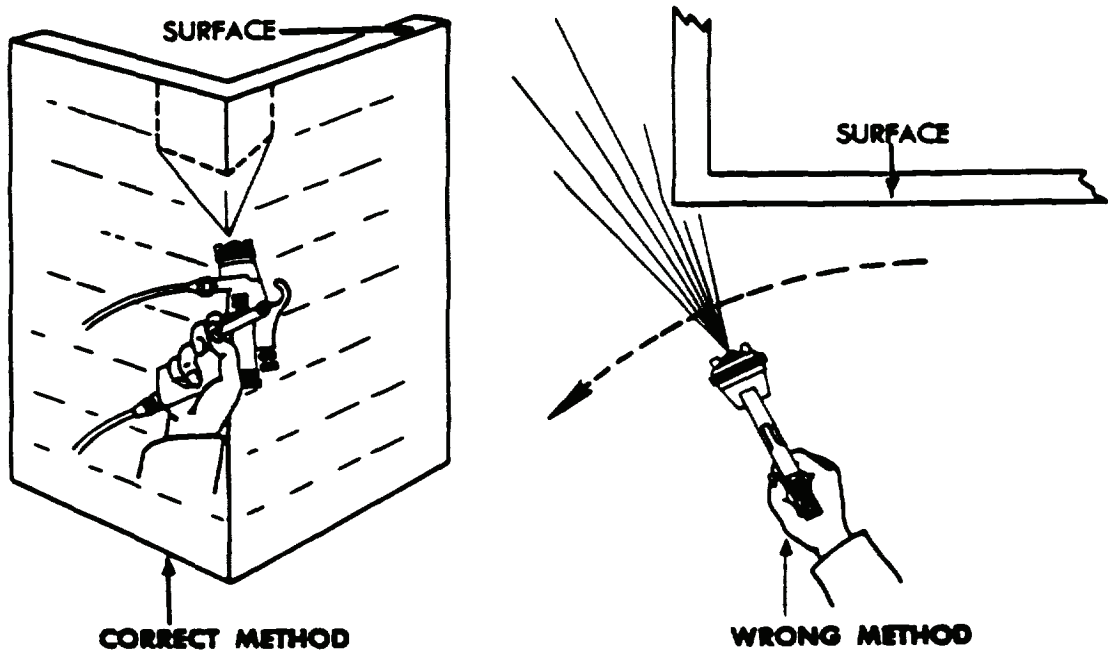
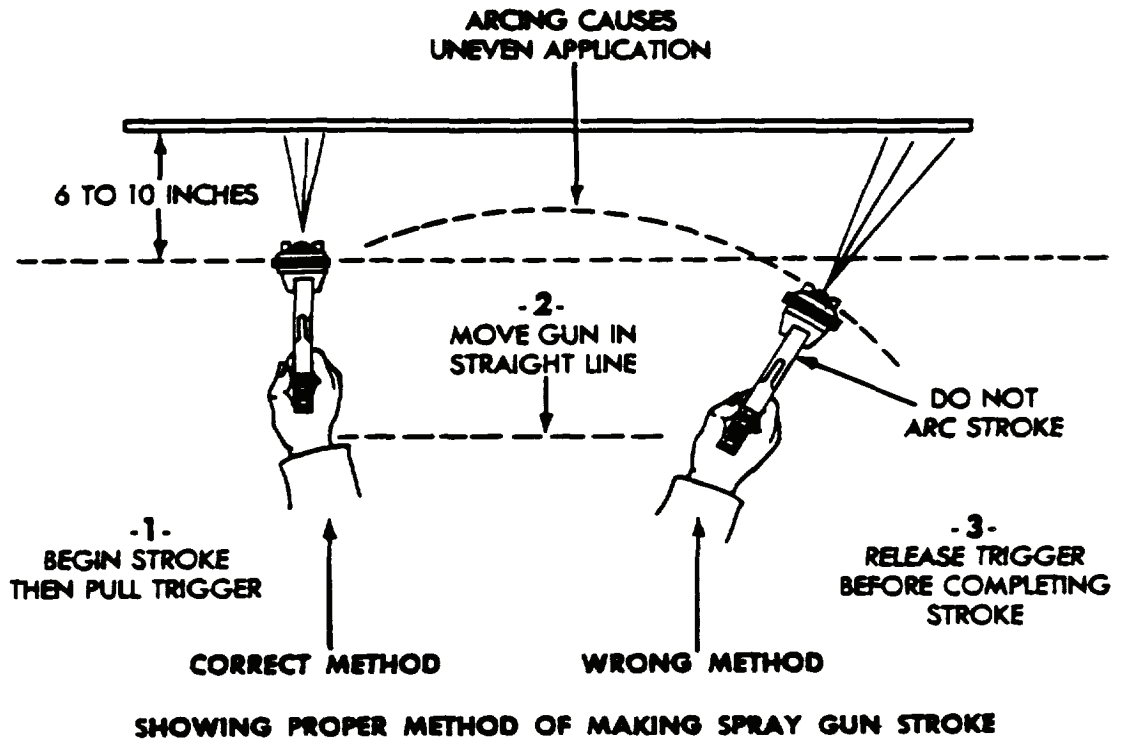

Figure 13-2. Proper Spray Gun Strokes

SPRAY GUN TECHNIQUES (continued)**Masking**

When spraying, cover or mask all parts such as windows, gages, lubrication fittings, instruments, and other parts which are not to be painted.

Small areas or irregular-shaped parts are covered with crepe-backed masking tape. On larger areas, a sheet of paper slightly smaller than the part to be masked is used, with the paper being held in place by a strip of masking tape, which overlaps the edge of the paper, and holds the paper to the surface being masked. Masking tape is available in various widths and is a convenient material with which to work when covering irregular outlines. The method of applying and trimming the tape is shown in Figure 13-3.

Liquid or paste-like materials are also available to mask out areas where paint is not desired. After the paint is dry, these areas may be wiped or stripped clean.

When spraying vehicle engines, the use of cloth bandages and socks will protect rubber hoses, ignition wires, and flexible tubing, and save much time and material. Cut cloth bandage to fit object to be covered. Drawstrings at each end, with a string wrapped around the middle of the bandage and tucked under a flap, prevent overspray from striking the protected object. Fit sock over ignition wires and distributor cap, and use drawstring tie to secure it around base of distributor.

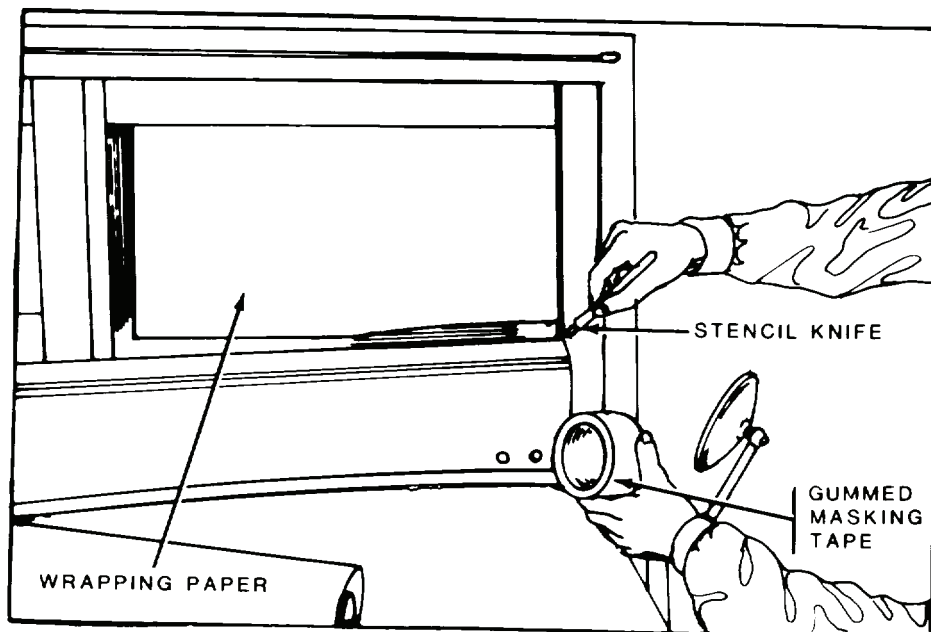
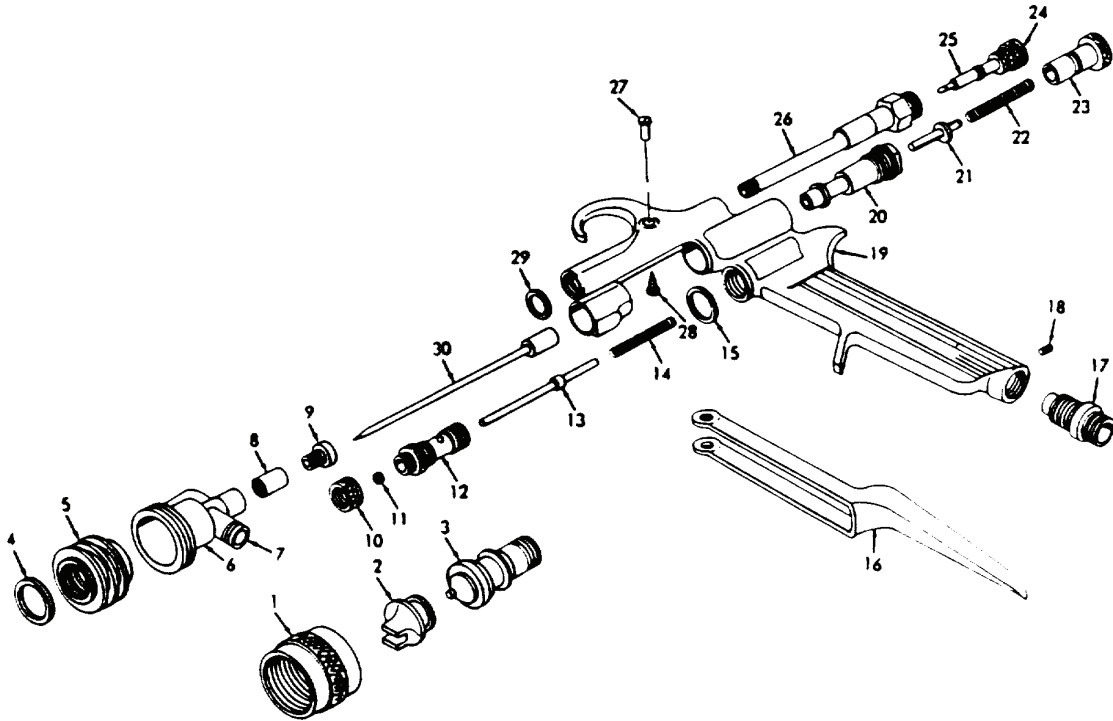

Figure 13-3. Masking

LEAKAGE AND CORRECTION

Material Leakage From Fluid Needle Packing Nut

This condition is caused by a loose packing nut or by dry fluid needle packing. To remedy this situation, remove and soften packing with a few drops of light oil. Re-install packing and tighten packing nut to prevent leakage. Refer to Figures 13-4 and 13-5.



Key for Figure 13-4

1. Air cap retaining ring	16. Trigger
2. Air cap	17. Air inlet nipple
3. Fluid tip	18. Setscrew
4. Gasket	19. Gun body
5. Baffle plate	20. Plunger cylinder
6. Housing	21. Needle plunger
7. Fluid nipple	22. Spring
8. Packing	23. Adjusting screw
9. Packing nut	24. Adjusting nut
10. Packing nut	25. Adjusting valve
11. Packing	26. Housing
12. Air valve body	27. Stud
13. Air valve	28. Screw
14. Spring	29. Gasket
15. Gasket	30. Fluid needle

Figure 13-4. Removable Spray-Head Type Spray Gun, Exploded View

Material Leakage From Fluid Needle Packing Nut (continued)

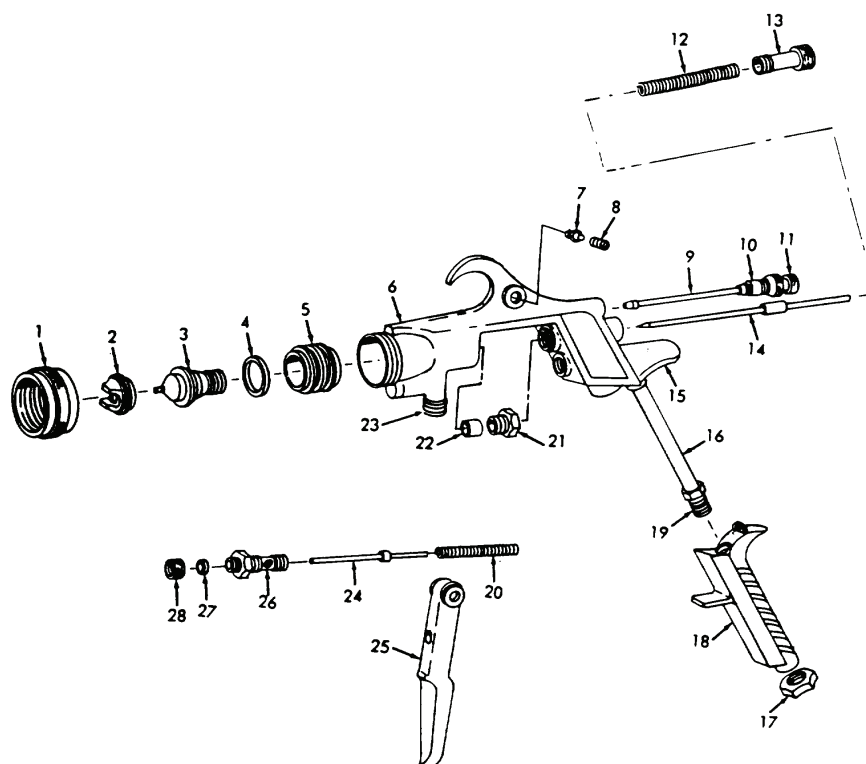

Key for Figure 13-5

1. Air cap retaining ring	15. Air valve plug
2. Air cap	16. Air tube
3. Fluid tip	17. Nut
4. Gasket	18. Gun handle
5. Baffle	19. Air inlet connection
6. Gun body	20. Spring
7. Trigger screw	21. Packing nut
8. Stud	22. Packing
9. Adjustment valve	23. Fluid nipple
10. Adjustment assembly	24. Air valve
11. Adjustment screw	25. Trigger
12. Spring	26. Air valve body
13. Adjusting screw	27. Packing
14. Fluid needle	28. Packing nut

Figure 13-5. Solid-Body Type Spray Gun, Exploded View

Material Leakage from Fluid Needle Packing Nut (continued)**Air Leakage from Front of Gun**

This condition is caused by the air valve not seating properly due to:

- Foreign matter on the valve or seat.
- A worn or damaged valve or seat.
- A broken air valve spring.
- A sticking valve stem due to lack of lubrication.
- A bent valve stem.
- A tightly closed packing nut.

Material Leakage From Front Of Gun

This condition is caused by the fluid needle not seating properly due to:

- A worn or damaged fluid tip or needle.
- Lumps of material or foreign matter lodged in the fluid tip.
- A tightly closed packing nut.
- A broken fluid needle spring.
- An improper size needle.

Jerky or Fluttering Spray

In pressure or suction-feed guns, this condition is caused by air leakage into material line due to:

- A lack of sufficient material in the container.
- Tipping the container at an acute angle.
- An obstructed fluid passageway.
- A loose or cracked fluid tip in cap.
- A loose fluid tip or damaged valve seat.

Material Leakage from Fluid Needle Packing Nut (continued)**Conditions Which Apply Only To Suction Feed Are**

- Material being too heavy for the suction feed.
- A clogged air vent in container lid.
- A loose, dirty, or damaged fluid inlet connection.
- The material feed tube is resting on bottom of container. Refer to Figure 13-6.

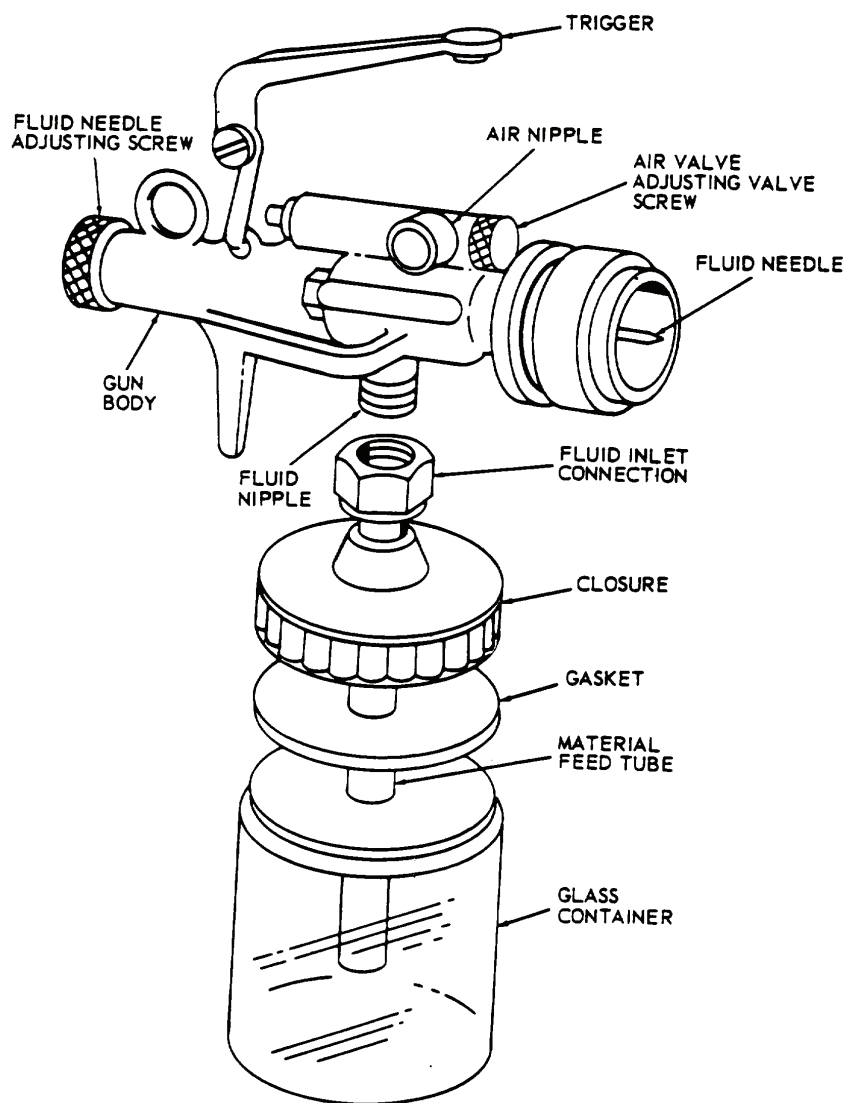

Figure 13-6. Attached-Container Type Spray Gun

Defective Spray Patterns

Heavy Top Pattern Is Due To:

- Horn holes that are partially plugged.
- An obstruction on top of fluid tip.
- Dirt on air cap seat or fluid tip seat.

Heavy Bottom Pattern Is Due To:

- Horn holes that are partially plugged.
- An obstruction on bottom side of fluid tip.
- Dirt on air cap seat or fluid tip seat.

Heavy Right Side Pattern Is Due To:

- The right side of horn holes is partially clogged.
- Dirt on right side of fluid tip.
- On a twin-jet cap, right jet is clogged.

Heavy Left Side Pattern Is Due To:

- Left side of horn holes is partially clogged.
- Dirt on left side of fluid tip.
- On a twin-jet cap, left jet is clogged.

NOTE

To remedy conditions described in above steps, determine if obstruction is on air cap or fluid tip. Rotate cap one-half turn and spray a test pattern. If defect is inverted, obstruction is on air cap. If defect is not inverted, obstruction is on fluid tip. Clean air cap as instructed in paragraph for Care of Spray Equipment. Refer to Figure 13-7 for examples of conditions described above.

Defective Spray Patterns (continued)

Heavy Center Pattern Is Due To:

- Spray width of adjusting valve is set too low.
- Twin-jet cap, because the atomizing pressure is too low, or the material is of too great a viscosity.
- Pressure-feed fluid pressure is too high for air cap's capacity.
- Nozzle is too large for material being used.

Split Spray Pattern: Split spray pattern is due to an imbalance in air and fluid pressure.

NOTE

To remedy conditions in heavy center pattern and split spray pattern above, read just atomizing pressure, fluid pressure, and spray width adjustment until desired spray is obtained. Refer to Figure 13-7 for examples of conditions described above.

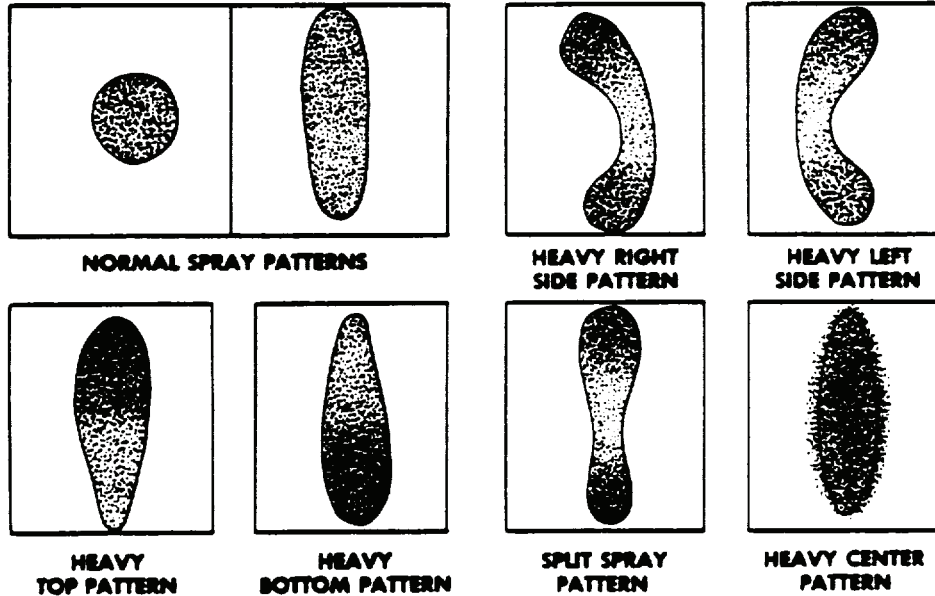

Figure 13-7. Defective Spray Patterns

Defective Spray Patterns (continued)

Orange Peel Finish. A common cause of this effect is use of improper or inferior thinner. With some thinners and paints, this condition may be noticed at certain times of the year due to atmospheric changes. Other causes are:

- Insufficient atomization.
- Gun is held too far from surface.
- Gun is held too close to surface, allowing air to ripple surface.
- Material is not thoroughly dissolved or agitated.
- With synthetics and lacquers, drafts exist in finishing room.
- With synthetics, there is low humidity.
- Improper (generally high) viscosity. Material should be reduced to specification requirements.

Streaks in Finish. Streaks are caused by:

- Tipping gun, thereby causing one side of pattern to deposit more material than the other side. Refer to Figure 13-8, Spray Painting Faults.
- An improper spraying pattern.

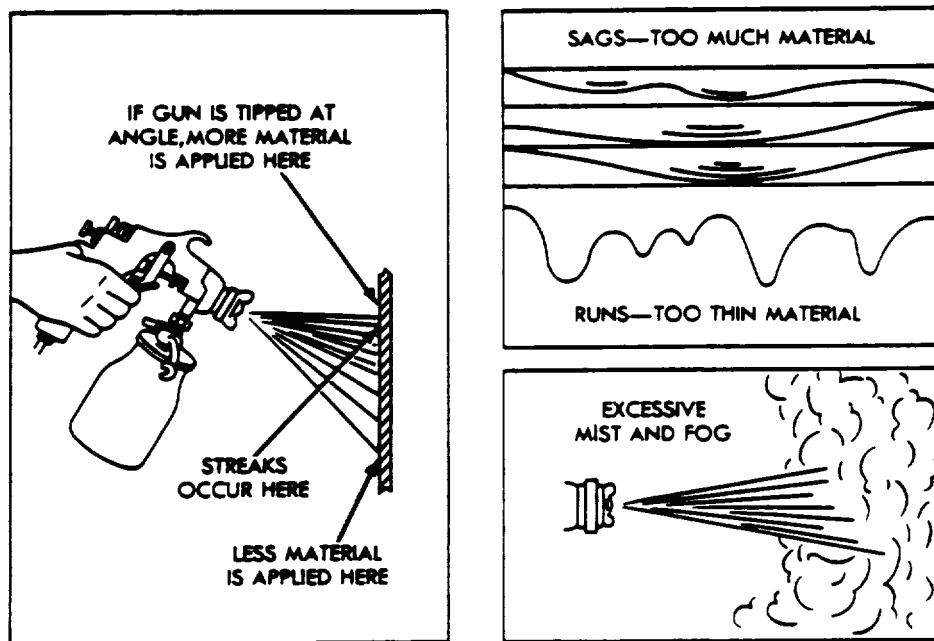

Figure 13-8. Spray Painting Faults

Defective Spray Patterns (continued)

Sags And Runs In Finish. Sags and runs are caused by:

- Tipping gun, resulting in an uneven deposit of material.
- Too much material on surface due to too much pressure, or gun travel that is too slow.
- Improper (generally high) viscosity. Material should be reduced to specification requirements.

Mist or Fog. This condition is caused by high atomization due to:

- An atomizing pressure that is too high.
- Wrong air cap for material used.
- Wrong fluid tip for material used.
- In pressure-feed systems, fluid pressure is too low.
- Incorrect stroking.
- Gun is held too far from painting surface.

Starving. This condition is caused by insufficient air reaching spray gun due to:

- Waste in air transformer is packed too tightly, or air transformer is clogged with corrosion or dirt.
- Air cocks are too small.
- Air lines are clogged.
- Air line is of an improper diameter.
- Inadequate air supply. This refers to volume of air that is being delivered by the compressor, and not necessarily pressure at which air is delivered.
- Air intake is clogged.

CARE OF SPRAY EQUIPMENT

A spray gun is an instrument that has been designed and machined to close tolerances. Handle it with care so that the balance between the functional parts is not destroyed. Spray guns and related equipment require cleaning immediately after use. Paint that has hardened in a gun or hose is extremely difficult to remove, and usually causes a malfunction of equipment. Be sure that solvent used to clean equipment is one in which finishing material is soluble. Be sure to read instructions that come with pressure can regarding preservation of nozzle.

Suction Cup Type

Remove cup, keeping fluid stem inside cup or container. Refer to Figure 13-9, then hold a cloth over air cap and pull trigger. This directs air into fluid passageways, and blows any paint that may be in gun back into container. After cleaning out cup, clean gun by spraying a small amount of clean naphtha or thinner through it. Extreme care should be exercised in removal of fluid top so as not to split the tip or otherwise damage it or fluid needle. When loosening fluid tip, trigger of gun should be compressed so that needle is not in contact with tip; this eliminates any possibility of splitting the tip due to friction or sticking that is caused by dried paint. The entire spray gun should never be immersed in naphtha or thinner, as this removes lubricants and dries out packings. Under no circumstances should air or fluid ports of a gun or nozzle be reamed with any substance harder than soft wood, as a deformation of spray pattern may result, and spray gun may be rendered useless. To prevent wear, working parts of guns should be kept lubricated with light machine oil. This requirement is especially true of the needle. The needle packing should also be kept pliable with an occasional drop of light lubricating oil.

Pressure Feed Type

Shut off air supply to pressure tank, refer to Figure 13-10. Release pressure in tank, and blow back fluid as described in suction cup type above. Empty and clean pressure tank. Place a container of clean naphtha or thinner inside pressure tank and install lid, making sure that fluid delivery tubes are immersed in container of naphtha or thinner, as shown in Figure 13-10. Apply pressure, and operate spray gun to clean hose and spray equipment. Disconnect fluid hose from gun and pressure tank and allow hose to dry thoroughly before reconnecting. Clean air cap and fluid tip as described in suction-cup equipment paragraph above.

CARE OF SPRAY EQUIPMENT (continued)

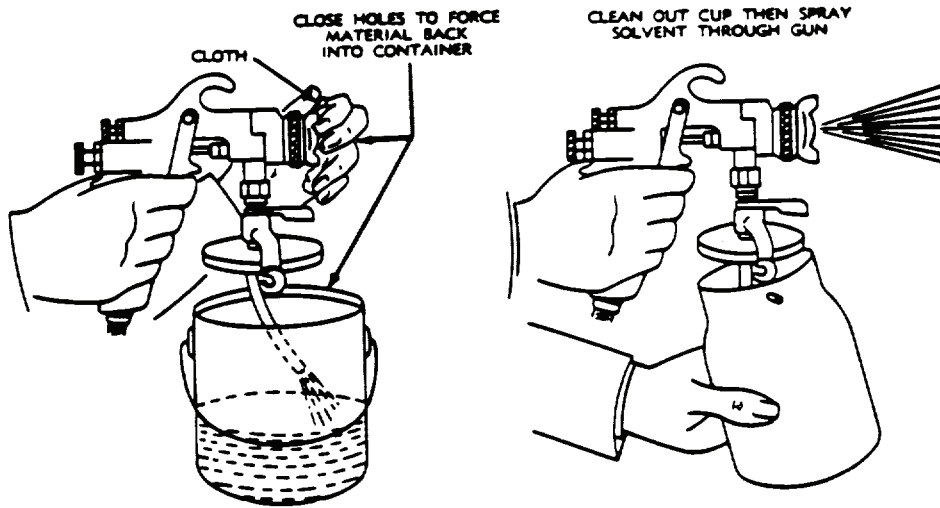

Figure 13-9. Spray Gun Cleaning

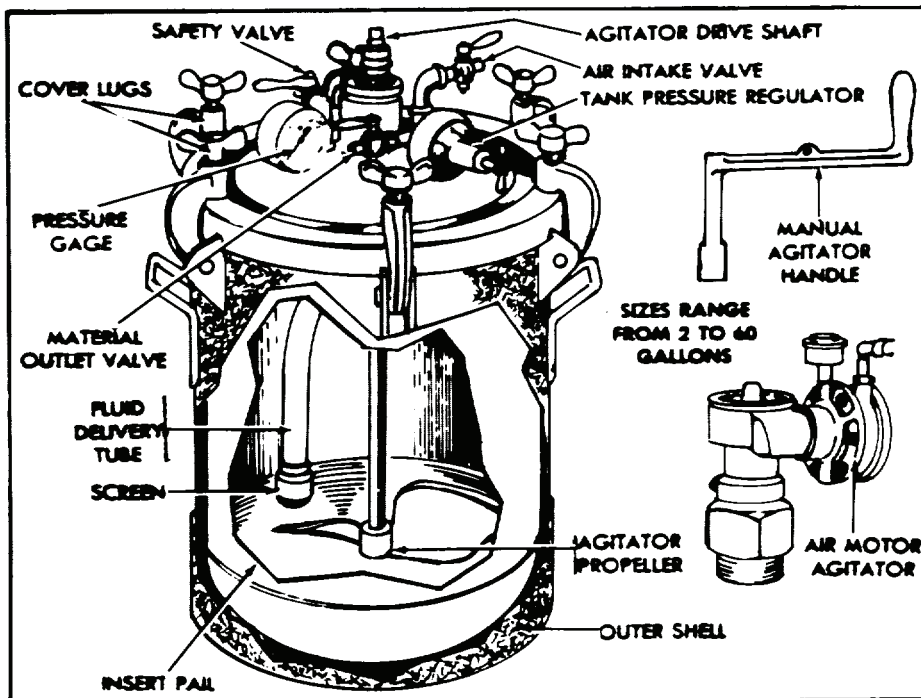

Figure 13-10. Pressure-Feed Paint Tank

TOUCHUP PAINTING

When equipment or material has spots from which protecting paint has disappeared, and the rest of paint surface is in a satisfactory condition, it is often advantageous to do a touchup, rather than a complete, paint job. Bare spots may have been caused by natural wear, abrasion, mechanical damage, or by rust or corrosion of surface under original paint. In such cases, it is necessary to clean material beneath spots and repaint using a method as near as possible to that used on original paint job.

Cleaning

Spots to be painted must be thoroughly cleaned so that no decay, dirt, rust, corrosion, etc., remains. Remaining paint should also be worked down to a feather-edge if it is desirable to hide the lap.

Painting

While touchup painting may be accomplished by a brush method, spraying is superior because edges of new paint can be feathered out to blend with old surface. If old and new colors match, areas of new paint will not be noticeable. In touchup work, use fillers, primers, and paints that are compatible with existing undercoats, finish coats, etc. General instructions for spray painting are also applicable to touchup work.

ADDITIONAL SPRAY EQUIPMENT

AIR COMPRESSORS

An air compressor is a mechanism designed to supply compressed air continuously at a predetermined pressure and volume. Compressors designated for spray painting are of two general types: single-stage and two-stage. These can be further divided into many other types, some of which are portable or stationary, unloaded or pressure-switch controlled, have horizontally or vertically mounted tanks, are air or water cooled, and have a gasoline engine or an electric motor drive. Technical Manuals for air compressors are listed in AMC Pamphlet 750-9.

Single-Stage Compressors

A single-stage compressor as shown in Figure 13-11, is one having one or two cylinders in which air is drawn from the atmosphere, compressed to a usable pressure, and delivered through an after cooler to an air receiver. Compressors of this type are intended for use where maximum pressures do not exceed 100 Pounds Per Square Inch (PSI).

Two-Stage Compressors

A two-stage compressor as shown in Figure 13-11) is one in which a relatively large cylinder first compresses air to an intermediate pressure. Air compressed to this point is delivered through an intercooler to a small cylinder where it is compressed to final pressure. It is then delivered through an after cooler to air receiver. A system of this type is intended for use where required pressures exceed 100 Pounds Per Square Inch (PSI). Such pressures will be encountered infrequently in everyday painting.

ADDITIONAL SPRAY EQUIPMENT (continued)

Gasoline Engine Drive

Gasoline engines of approximately three to five horsepower are used with compressors under the following conditions: Where electric current is not available; where spray painting systems are used in localities served with different types of current; and in localities where insufficient current is supplied.

Electric Motor Drive

A majority of spray painting compressors are powered by electric motors of one fourth (1/4) to five (5) horsepower. Use of a system of this type is confined to locations in which proper current is available. Electric motor-drive is generally chosen for more or less permanent installations, while a gasoline drive is preferred where portability is a prime consideration.

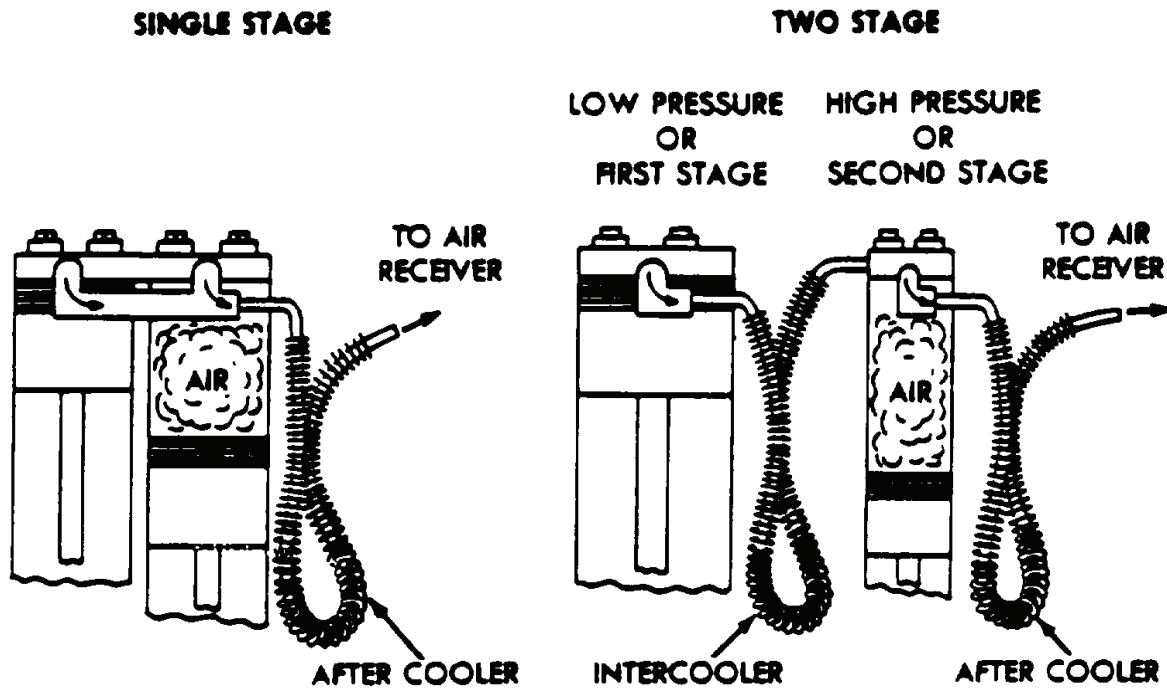

Figure 13-11. Single and Two-Stage Compressors

Unloader and Pressure Switch Control

Engine-driven compressors have unloaders which automatically disconnect compressing cylinders from air storage tanks and allow engine to continue to run at an idling speed until tank pressure decreases to a preset minimum pressure. When tank pressure reaches its preset minimum, an unloader valve automatically advances engine throttle, opens valves, and causes pressure to be built up again. Electric motor-driven compressors have a pressure switch which shuts off the motor when a predetermined pressure has been established and restarts it when pressure has fallen to a predetermined point.

ADDITIONAL SPRAY EQUIPMENT (continued)**Horizontal and Vertical Tanks**

Normally, compressor tanks are mounted in a horizontal position, serving as a base for the compressing unit. Where space is limited or where ground clearance or a corner installation is important, tanks can be mounted in a vertical position.

Air or Water Cooled Compressors

Physical process of compression produces heat, and for that reason it is particularly important that air compressors be adequately cooled. Most compressors intended for use with spray painting equipment are air cooled. To accomplish this, exterior surfaces of cylinders, intercoolers, and after-coolers are greatly increased in area by use of fins. Increased surface area allows heat to be radiated more rapidly. Larger compressors, when used continuously, cannot be adequately cooled by air. Such compressors use a water cooling system consisting of a radiator, pump, fan, and water jackets built around cylinders and are similar to those of automobile engines.

Truck Outfits

Air compressors, usually with gasoline engines for power, are often mounted on light, easily moved trucks. These portable units are ideal where painting is to be done at various locations.

INSPECTION AND LUBRICATION OF COMPRESSORS**Gasoline Engine****CAUTION**

Do not make adjustments or repairs to gasoline engines unless qualified to do so.

Gasoline engine driven air compressors are furnished with engines manufactured by many different companies. Generally speaking, they are of low horsepower and simple construction. For instructions on how to lubricate and adjust, refer to pertinent Technical Manuals. Adjustments to carburetor, gasoline lines, and ignition systems should not be made in or near paint shop. While maintenance and repair of gasoline engines is not the responsibility of the painter, he/she should be sufficiently familiar with them to correct any minor stoppages caused by improper adjustment. Most gasoline engines used on air compressors are adjusted at the factory to run at a constant speed and no throttle adjustments should be necessary.

ADDITIONAL SPRAY EQUIPMENT (continued)**Electric Motor**

For lubrication of electric motors, refer to pertinent Technical Manuals. Adjustment of electric motors, even of a minor nature, is not the responsibility of the painter and should be undertaken only by qualified personnel. It is, however, the responsibility of the operator to see that electric motors on his/her compressor are not damaged through improper use. All electric motors, when overloaded, overheat, usually very rapidly. If this condition is allowed to persist for even a brief interval, insulation on windings may burn away. Use of fuses and circuit breakers is intended to prevent this, and operator should familiarize himself with them. In no event should fuses be shorted or circuit breakers tied down.

OPERATION OF COMPRESSORS**Installation**

Proper operation of a compressor system depends to a great extent on correct initial installation of equipment. The following points are important to proper installation: Electrical wiring, whether for a permanent or portable installation, presents a fire hazard at all times, and should be installed and inspected by a qualified electrician, as fire in a paint shop is devastating and almost impossible to control. Overload protection should be furnished for the electrical circuit; compressors should be located in an adjacent room and not in the paint shop, as this reduces the fire hazard considerably, improves the performance of the compressor, and reduces operator fatigue caused by compressor noise. Permanent installations should be at least one foot from adjacent walls to allow free air circulation over the cooling fins; air intakes should be piped to the outside of the building, where they can pick up clean, cool air; air pipe lines should be of sufficient size; an air compressor should be mounted on a solid foundation, because unless the weight is equally distributed, excessive vibrations will result in noisy operation and may cause a break in the tank supports or the compressing equipment; and the compressor should be installed so that it is level, with regard to a horizontal tank, and plumb, in the case of a vertically mounted tank, as this will assure the proper function of compressor oiling system.

Replacement

Like all mechanical devices, air compressors eventually wear out and should be replaced or rebuilt when: operational efficiency has decreased through wear and mechanical adjustments fail to restore it; or there is an insufficient air output which cannot be corrected by normal equipment adjusting; or the time interval from cut-in to cut-out is prolonged to the point of wasting power (a 50 % deviation from expected time interval is sufficient reason for replacing or rebuilding system).

Draining

The operation of compressing air, which always contains some moisture, induces condensation. Water condensed in this manner collects in the air receiver of the compressing outfit and must be removed each day by draining through the air receiver petcock. Proper location of the air intake will cut down the amount of water condensed in this manner.

OPERATION OF COMPRESSORS (continued)**Servicing**

Servicing of air compressors by qualified personnel should be confined to instructions given in this paragraph. Any further servicing by Maintenance personnel should be performed in accordance with Technical Manuals for the specific compressors.

Tanks (Paint Containers)

Material containers for spray painting systems are metal or glass vessels which are connected to the spray gun. These containers serve as supply reservoirs for the material to be sprayed, and are of a cup or tank type.

CAUTION

Painters planning to use coatings formulated with chlorinated solvents must remove all aluminum components from their painting system and replace with aluminum-free or stainless steel

Cup Containers

Containers of this type are generally used where a variety of colors in rather small quantities are to be sprayed. There are two types: suction and pressure feed. Pressure-feed cups are recommended for small quantities of enamels, plastics, and other materials too heavy for suction feed, and where fine adjustment and speed of application are desired. The commercial preloaded and precharged pressure spray cans are not rechargeable.

Tanks

Spray gun tanks are material containers for pressure-feed systems and provide a constant flow of paint at a uniform pressure. Their capacities range from two to 55 gallons. They consist of a container with a clamp-on lid, a fluid tube, outlet valves, a pressure gage, an agitator, and a safety valve. They also have an insertable paint container. They are furnished with either a top or bottom outlet and various accessories. There are two distinct types: Regulator type tanks offer the advantage of supplying large quantities of material to the gun under accurately controlled fluid pressure. Regulator-type tanks are frequently further subdivided into single and double regulator types, depending on whether the control is applied to the material pressure alone or to both the material and gun pressures. Regulator-type tanks are equipped with a pressure regulator, safety valve, release valve, etc., and are operated with different pressures on the air line and material. Equalized pressure tanks are equipped with only a safety and release valve, and operate with the same pressure on the air line and on the material.

Insert Containers

Insert containers are pail-like metal vessels designed to sit inside the tank. This eliminates cleaning the tank and facilitates the rapid change from one color to another. Their use permits several batches of material or colors to be mixed ahead of time. This construction also permits feeding directly from small cans of paint instead of from the full-sized container inside of the tank.

OPERATION OF COMPRESSORS (continued)**Agitators**

Certain materials require constant or frequent agitation while in the tank, and to meet this requirement, tanks are frequently supplied with mechanical agitators which can be activated by an air motor, by an electric drive, or by a manual crank.

Material Containers

Most metal containers are rugged, substantially built and should present few, if any, operating difficulties. If regulator-type tanks are properly adjusted, air vents are kept free, and agitators are used when needed, little maintenance will be required beyond thorough and adequate cleaning procedures. Mounting a tank upon a dolly greatly extends the working area when used for multiple-gun operation. Tanks are available which provide for simultaneous two-gun operation.

Precautions

Observing the following precautions will insure the proper operation of material containers.

WARNING

Never remove cover from a pressure-feed container unless pressure has been released. Failure to do so may cause death or injury to personnel.

Clean thoroughly after use, as many spray gun malfunctions can be traced to improper cleaning of the material container; be sure the fluid and air valve connections on the container are the proper size for the hose being used; test the tank safety valve regularly; keep the material containers full, as they do not function efficiently when nearly empty; and use the agitator regularly (where paint is being applied very rapidly, agitators are seldom needed, yet failure to agitate certain materials results in the formation of a surface skin which rapidly clogs filters and hose).

OPERATION OF COMPRESSORS (continued)**Hoses**

Construction. Two types of hoses are used with spray guns, and fluid. An air hose has a red or orange cover while a fluid hose is black. The inner tube of a fluid hose is constructed of a solvent-resisting material that is generally impervious to any of the common solvents used in paint.

Size. Hose of adequate inside diameter must be used with all spray gun systems. Too often a spray gun is blamed for improper paint feeding, or a material is considered of inferior quality, when the real cause of the trouble is low air pressure at the spray gun. Usually, this condition is caused by a hose that is too small. As seen in Table 13-1, there is a natural pressure drop whenever compressed air is transmitted, and the amount of this pressure drop increases as the hose gets smaller.

Pressure Drop

Table 13-1 shows the air pressure drop expected from various lengths of one-fourth and five-sixteenths inch hose when used with a spray gun. For example, with 70 pounds of air pressure at the transformer, only 47 and one-half pounds of pressure (70 minus 22.5) will exist at the spray gun when 25 feet of one-fourth inch hose is used to connect the two units.

OPERATION OF COMPRESSORS (continued)

Pressure Drop (continued)

Table 13-1. Drop in Air Pressure

Air pressure drop at spray gun (psi)						
Air pressure at Transformer (psi)	5-foot length	10-foot length	15-foot length	20-foot length	25-foot length	50-foot length
Air hose + 1/4 inch						
4	6	8	9 1/2	11	12 3/4	24
0	7 1/2	10	12	14	16	28
5	9	12 1/2	14 1/2	16 3/4	19	31
0	10 3/4	14 1/2	17	19 1/2	22 1/2	34
6	12 1/4	16 1/2	19 1/2	22 1/2	25 1/2	37
0	14	18 3/4	22	25 1/4	29	39 1/2
7						
0						
8	2 1/4	2 3/4	3 1/4	3 1/2	4	8 1/2
0	3	3 1/2	4	4 1/2	5	10
9	3 3/4	4 1/2	5	5 1/2	6	11 1/2
0	4 1/2	5 1/4	6	6 3/4	7 1/4	13
Air hose + 5/16 inch	5 1/2	6 1/4	7	8	8 3/4	14 1/2
4	6 1/2	7 1/2	8 1/2	9 1/2	9 1/2	16
0						
5						
0						
6						
0						
7						
0						
8						
0						
9						
0						

OPERATION OF COMPRESSORS (continued)**Cleaning**

The fluid hose should be cleaned immediately after use. In no event should a fluid hose be left uncleaned overnight.

Storage

When not in use, the hose must be coiled and hung where it will be free from possible damage.

Valves and Gages

Valves and gages used on spray painting equipment are of rugged construction and normally will need little attention to insure their correct operation. The following suggestions may be helpful in maintaining this equipment in good condition:

- Keep valves free from paint by wiping with a cloth dipped in solvent or thinner. Do not immerse valves in solvents or thinners, as this will dry out the packing.
- Be sure that valve nipples are of the correct size for the inside diameter of the hose being used. Incorrect mating of hose and nipple is a common cause of spray gun malfunction.
- Do not repair air gages in the field. Have these done by experienced and qualified personnel using the special tools and skills required for their proper adjustment.

Air Transformers

An air transformer, or separator, is a device which condenses oil and moisture, regulates and filters the air, and provides outlets to which spray guns and dusters may be connected. Refer to Figure 13-12, Air Transformer Installations.

Operation

Oil and moisture are collected by the baffles and filter pack, allowing only clean, dry air to reach the spray gun. Further drying may be accomplished by the use of cartridges filled with a desiccant, such as silica gel, and installed in the outlets.

Oil and moisture collect at the bottom of the air separator or transformer and should be removed daily. Refer to Figure 13-12, Air Transformer Installations.

OPERATION OF COMPRESSORS (continued)

Installation

Proper installation of the air transformer is essential to maintain correct operation. The following points are to be observed:

- Install the transformer at least 15 feet from the compressor.
- Air takeoffs from the compressor line to the transformer should be from the top of the line.
- The compressor air line to which the air transformer takeoff is attached should slant toward a permanently installed drain leg which should be drained daily. In localities where regulated air is available and only cleaning and filtering is needed, an air conditioner may be used to supplant the air transformer. The size of all necessary air lines are shown in Figure 13-12, Air Transformer Installations.
- Filter replacement. The filter pack in an air transformer should be inspected and replaced whenever it shows signs of becoming clogged by dirt or oil.

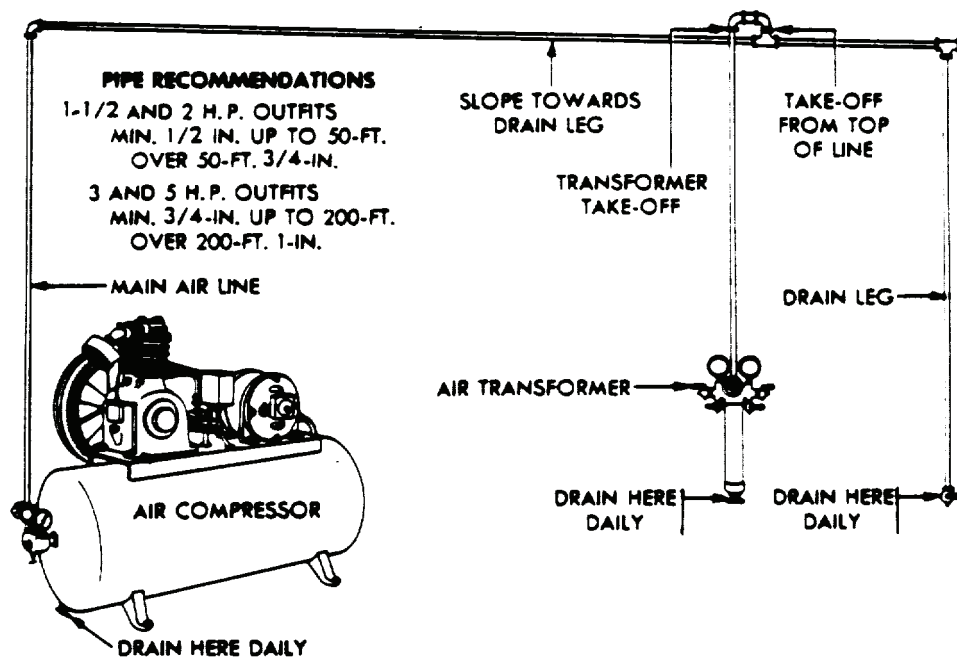

Figure 13-12. Air Transformer Installations

SHOP EQUIPMENT**Paint Booths**

A paint booth is designed to collect, filter, and exhaust the fumes arising from the use of spray paint equipment. Due to Occupational Safety and Health Administration (OSHA), Environmental Protection Agency (EPA), and specific state and local requirements, any large scale (more than touchup) painting must be done in a paint booth. This is to minimize the release of toxic fumes into the environment and protect workers.

Spray booths can be classified into two basic designs based on direction of airflow:

Sidedraft Booths. Sidedraft booths have horizontal airflow. These booths take advantage of momentum of the spray mist and can be used when painting small to medium articles.

Downdraft Booths. Downdraft booths have vertical airflow. These booths permit greater protection while allowing more freedom of movement for the painter.

Spray booths range in size from small, bench-type models to huge chambers capable of holding a large airplane. The basic consideration in determining the size of a spray paint booth is ensuring adequate space to permit the painters easy access to the top and sides of the object. If the object is transported by conveyor, the booth must be sufficiently long to allow coating within the time the object remains inside the booth.

Booth exhaust air must be replaced for plant environmental control. The spray booth can be equipped with filter doors or fresh air inlets to reduce the amount of dust entering the booth. Air should enter the booth at low velocity (200 feet per minute (fpm) or less) and in the same direction as it is being exhausted to avoid unnecessary turbulence.

SHOP EQUIPMENT (continued)

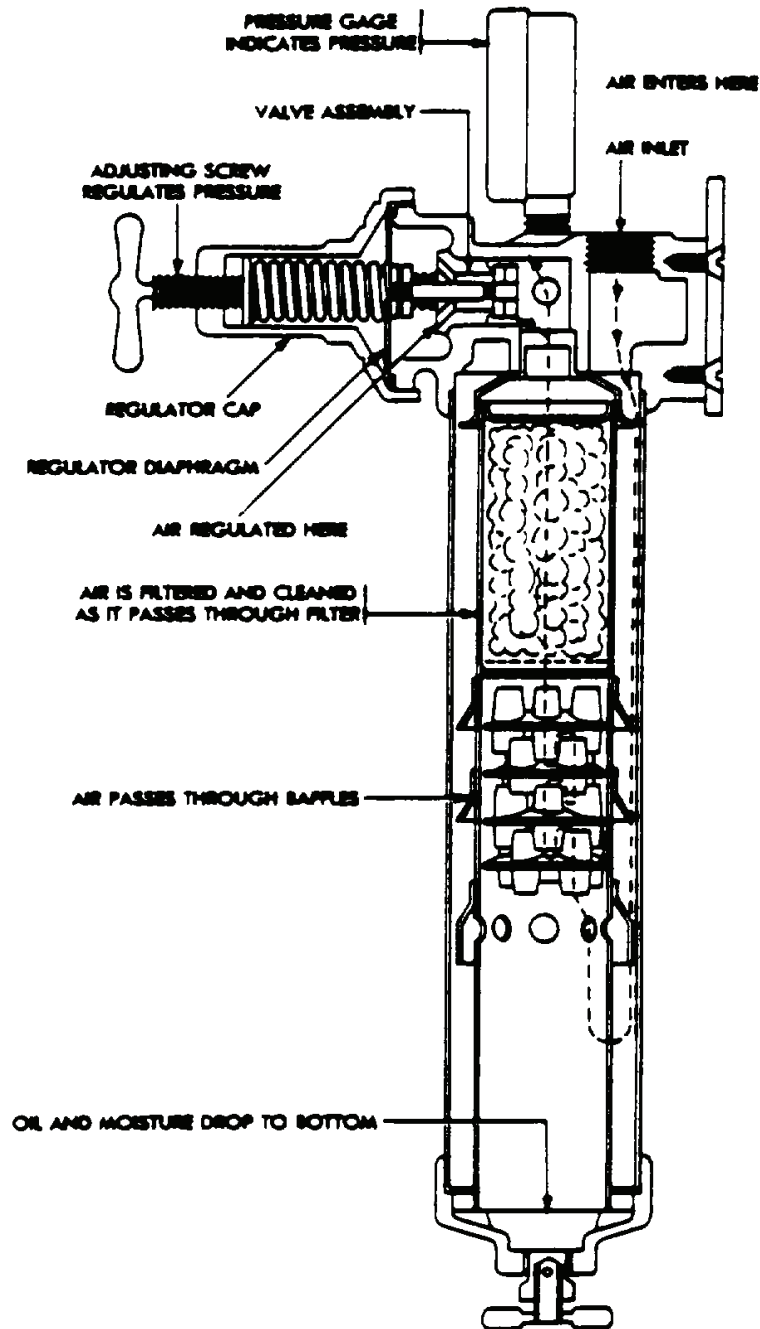

SHOP EQUIPMENT (continued)

The booth air cleaning section not only removes paint mist from the exhausted air but acts as a means of air distribution within the booth. There are several types:

Baffle Type. An arrangement of metal baffles is simplest and provides a constant flow of air. Mist removal and clean-up difficulties limit its use to low production applications.

Dry Filter. These booths combine low cost with highly efficient paint mist removal, but have the disadvantage of a variable airflow. The airflow continuously decreases to a point where the filters require replacement. Dry filters must be disposed of carefully or a fire hazard will be created.

Water Wash. These incorporate various combinations of water curtains and sprays to scrub the paint mist from the exhausted air. They have the advantage of constant airflow, inherent fire protection, and high mist removal, but at a greater cost.

Thought should be given as to how the booth will be maintained. Maintenance requirements can be reduced if:

- The booth is lined with strippable coating, such as wrapping paper or masking tape.
- Air filters are disposable.
- The glass shields over the booth lights are cleaned and coated with a layer of white petroleum grease.

Portable Floodlights

Portable floodlights provide good illumination directly on areas to be painted. Their use will avoid uneven paint coverage. All lights used should be of the vapor proof type.

Can Shakers

A motor-driven paint can shaker (mixer) is a valuable piece of paint shop equipment. It saves considerable time and eliminates stirring by hand and paddle.

END OF WORK PACKAGE

BRUSH OR ROLLER APPLICATION

SCOPE

This Work Package (WP) details equipment selection, use, and care, required for painting of Army materiel.

WHEN TO USE BRUSH OR ROLLER APPLICATION

Brush or roller application is used when:

- The volume of work does not justify setting up spray apparatus.
- Spray equipment is not available or is inaccessible to job.
- The operation is that of priming wood or other porous surfaces.
- The task of masking-out non-painted parts is extensive.
- Mist from spray gun would damage surroundings or create a fire hazard.
- Respiratory equipment, required for spray application, is not available.

SELECTION OF BRUSHES AND ROLLERS

Factors determining proper selection of a brush, as shown in Figure 14-1, for a specific task are:

- The material to be applied.
- The nature of surface on which material is to be applied.
- The area to be covered.

For Paints

Flat brushes with long soft bristles or hair are required to apply paint. The width will vary with area and nature of surface to be covered.

For Enamels

Brushes used for enamels should be relatively large, with a chisel point. Skunk hair (Fitch), rubber-set, varnish brushes with moderately soft and fine bristles are best. This type of brush, slightly moistened with water, can be used to touch up a non-Chemical Agent Resistant Coating (CARC) surface by rebrushing coat, providing brushing is done soon after enamel film has been applied.

SELECTION OF BRUSHES AND ROLLERS (continued)

Paint Rollers

Paint rollers are replacing brushes more and more. There are three types: quench, fill, and power. The quench roller requires a tray for quenching with paint. The fill roller does not require a tray, but a funnel is needed for filling. Both rollers require buckets and/or trays for easy handling. The power roller has an electric motor that pumps paint directly from container to roller. These rollers are used mostly on large wall areas, floors, and ceilings. The material to be applied and the nature of surface to be treated are factors that will govern their usefulness.

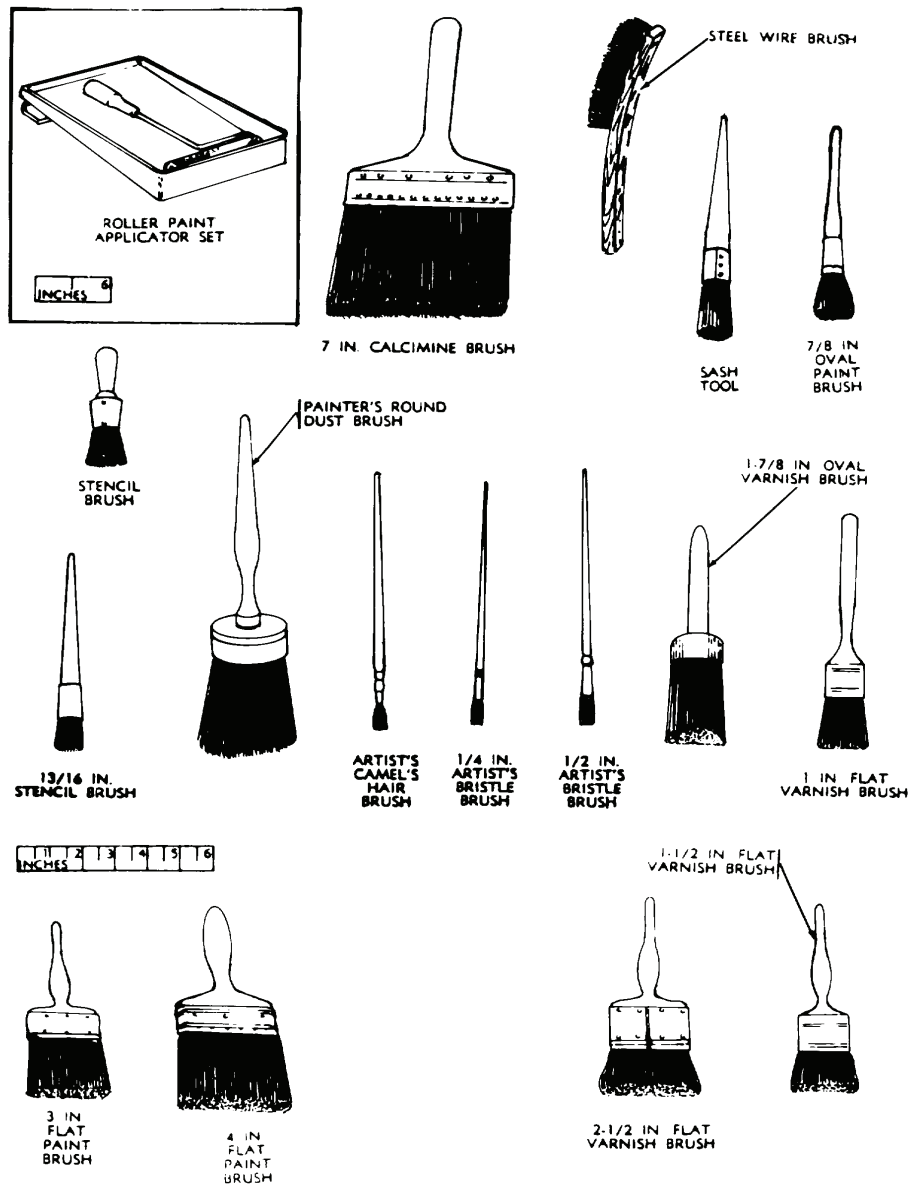

Figure 14-1. Types of Brushes and Rollers

BRUSHING VARIOUS MATERIALS

Brushing is used where rolling is impractical. A right-handed operator should start at right edge of surface to be painted and proceed toward left. Using this procedure, full paint brush is applied to uncoated surface by brushing back into wet film. By decreasing pressure at end of a stroke, brush marking is minimized. A left-handed operator should start at left edge of surface to be painted and proceed toward right, edge.

Paint

On exterior woodwork, use a long, sweeping, straight stroke.

Slow Drying Enamel

Make short strokes in one direction until a small area is covered, then go back over area with strokes at right angles to first, in order to obtain a smooth even coat. This operation is called "laying-off" the finish. Follow with an adjacent area of similar size before enamel in first area sets.

Brushing Technique: Refer to Figure 14-2, Brushing Techniques.

BRUSHING VARIOUS MATERIALS (continued)

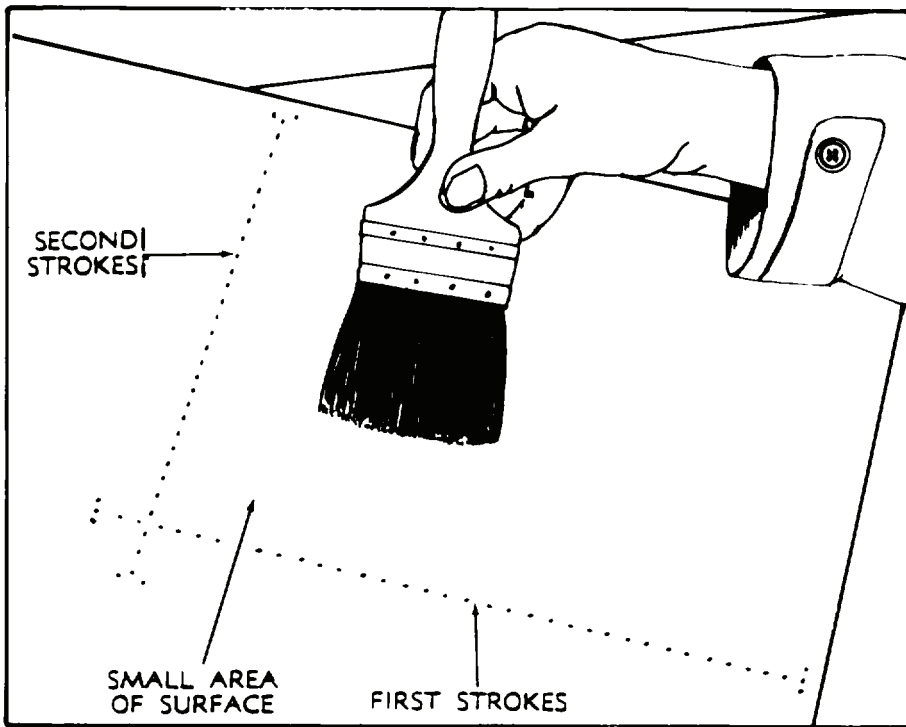

A. BRUSHING TECHNIQUE FOR VARNISH AND ENAMEL.

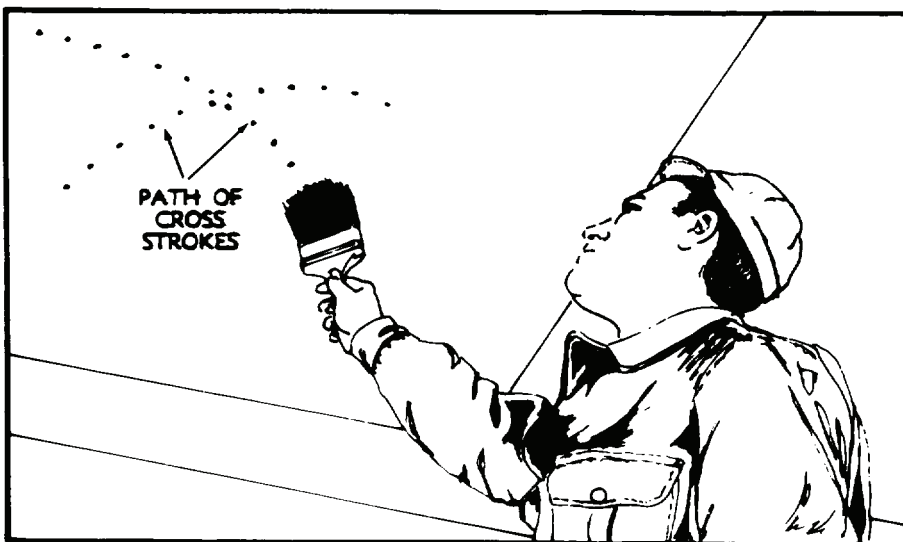

B. TECHNIQUE FOR PAINTING A CEILING.

Figure 14-2. Brushing Techniques (Sheet 1 of 2)

BRUSHING VARIOUS MATERIALS (continued)

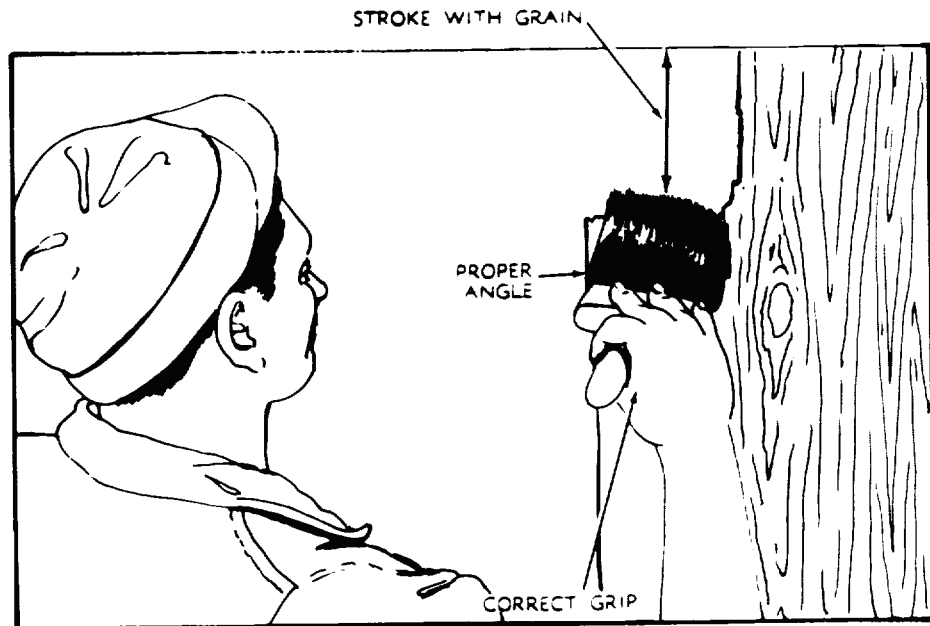

C. BRUSH TECHNIQUE FOR FLAT SURFACES.

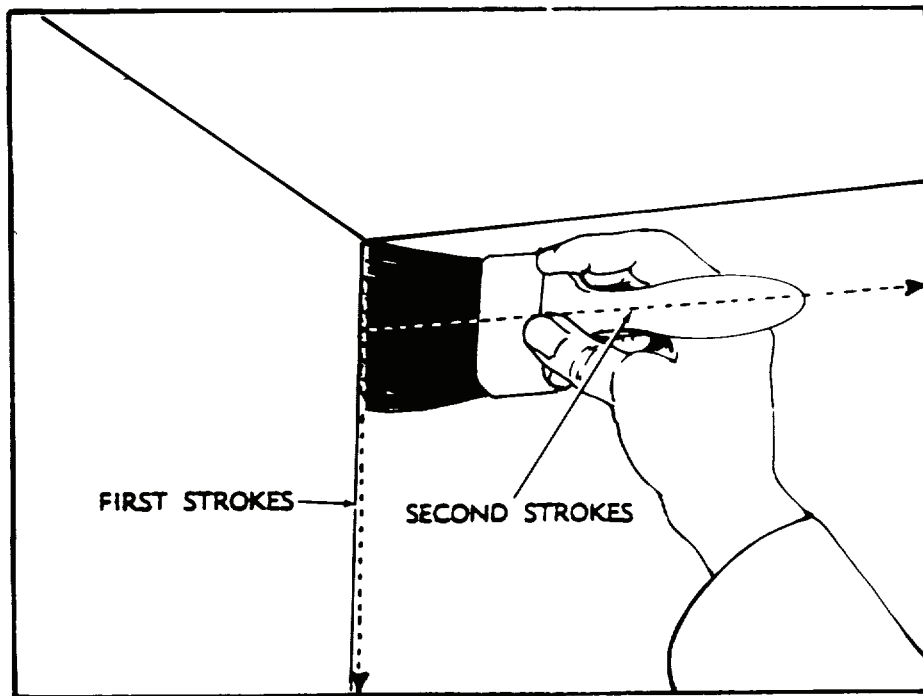

D. BRUSH TECHNIQUE FOR PAINTING IN CORNERS.

Figure 14-2. Brushing Techniques (Sheet 2 of 2)

CLEANING OF BRUSHES AND ROLLERS

In order to keep paint brushes soft and pliable, they should be cleaned immediately after use. Once material has been allowed to stand overnight, no amount of cleaning will restore original pliability or remove hardened material from heel of brush. Solvents or thinners used with material just applied by brush are best possible cleaners.

Steps in Cleaning

- Save cleaning materials by first pressing brush firmly against rim or side of paint container, thus squeezing out as much paint as possible.
- In the event paint has hardened in the brush, it should be softened and carefully worked out with a putty knife.
- Pour a small amount of brush cleaning fluid into a shallow, wide-mouthed container and work it thoroughly into the brush, making sure that fluid gets up to base of bristles.
- When this small amount of fluid is loaded with paint from the brush, discard fluid. Take a somewhat larger amount of fresh fluid and repeat operation as many times as necessary until all traces of pigment and paint disappear and bristles are soft and pliable.
- Paint rollers are cleaned in much the same manner. Use a pan instead of a pail and soften by following instructions given by the roller Manufacturer.

CARE AND STORAGE OF BRUSHES AND ROLLERS

The proper care of paint brushes and rollers requires use of a few basic rules:

- Never stand brushes, wet or dry, on their bristles. This will cause bristles to become permanently bent or deformed and will ruin the brush.
- A brush used periodically should be stored in a keeper, such as a container of linseed oil or another appropriate thinner. Suspend brush from a nail or hook so that bristles are covered with thinner but are not touching bottom of container.
- Brushes that are not frequently used should be thoroughly cleaned with proper paint thinner or cleaning agent. After drying, they should be stored in a wrapper to retain their shape.
- For care of rollers, follow Manufacturer's instructions.

Storage Overnight

Paint brushes in daily use should be kept overnight in a brush keeper. Immersion of cleaned brush in oil or thinner will assure that bristles will remain soft and pliable. Segregate brushes in their keepers according to type of material used. Use a recommended keeper for brushes used with Chemical Agent Resistant Coating (CARC); use a linseed oil keeper for brushes that are for use with paints and varnishes; place dope and lacquer thinner in keeper for brushes used with lacquers; use synthetic-resin enamel thinner for brushes that are used with enamels; and use A-A-51693, Alcohol, Dehydrated, USP, for brushes that are used with shellacs. A keeper cover should be used to prevent evaporation and contain flammable vapors of solvents and thinners. If necessary, drill a hole in brush handles for suspension in keepers.

- Use enough, solvent, or thinner in keeper so that bristles of brushes are covered. These brushes should not touch each other or bottom of container.

NOTE

Brushes used for Chemical Agent Resistant Coating (CARC), should be placed in brush keepers containing CARC thinner, or alcohol, respectively.

- For rollers, follow Manufacturer's instructions.

Indefinite Storage

When brushes are not to be used for a long time, they may be prepared for storage as follows:

- Clean thoroughly.
- Immerse in raw linseed oil or another appropriate thinner for a few days. This can be done in brush keeper.
- Remove brush from keeper and press out most of the thinner with no weight applied to bristles. Open package and repeat procedure every six months or less.
- Straighten bristles and wrap brush in paper. Brushes treated in this manner should be stored flat with no weight applied to bristles. Open package and repeat procedure every six months or less.
- A procedure similar to this should be followed for storage of rollers. Follow the instructions given by Manufacturer for these items.

MISCELLANEOUS EQUIPMENT**Scrapers**

Scrapers of various sizes, made of bronze, which do not produce sparks when rubbed on other metals or concrete surfaces, are used for cleaning paint residue from spray booths, the floor, and from metal and wood surfaces. Flexible carbon scrapers should be used on aluminum and magnesium since metal scrapers may leave deposits of metal. These deposits promote galvanic corrosion, and in some instances, could even cause shorting of electrical circuits.

Stencil Sets

Brass stencils: Brass stencils in one to four inch sizes are sometimes used for stenciling.

Paper stencils:

- Star-insignia cardboard stencils are available in various diameters.
- Paper stencil sets are available in various sizes.
- Gummed-back paper stencils. Gummed-back paper stencils are available for applying registration numbers.

Miscellaneous Tools and Supplies

- Layout Tools. Straightedges, a yardstick, a steel square, and dividers are used for laying out lines to guide in location of letters and insignia when stenciling. Guidelines can also be made by snapping chalked string against surface to be painted.
- Hydraulic jack. A good hydraulic jack is required for removal of vehicle wheels before painting. Wooden or iron horses are sometimes needed for this operation to support vehicle with its wheels removed. Inspect jacks prior to each use to ensure that they are safe for use (i.e. no leaks, cracks, etc.).
- Supplies for preparing surfaces. Painting, removing, cleaning, rust-removing solutions, and sanding materials are required for preparing surfaces.
- Masking tape. Masking tape is required to cover all body parts that are to be protected from paint spray. Tape alone is used to mask small areas. For larger areas, such as windows, tape is used to fasten paper over area to be protected.
- Sanding disks. Sanding disks are used with a motor sander and polishing pads and solutions are used with an electric buffer.

Miscellaneous Tools and Supplies (continued)

MISCELLANEOUS EQUIPMENT

- Other tools. Other tools required in the paint shop include paint brushes, wire brushes for cleaning off loose paint and rust, and putty knives or scrapers for removing old paint. Razor blade scrapers are useful for removing paint from glass. A 16 ounce graduated glass container is needed for mixing paint and thinners in required proportions.
- Cloths. An abundance of wiping cloths is required for wiping off spilled paint and for cleaning spray guns and related equipment.
- Electric Sanders. Portable, motor-driven, disk or orbital sanders are occasionally required for smoothing a vehicle's body or fender before it is painted, although this is not usually work of paint shops personnel.
- Electric Buffers. Ordinarily, same tool is not used for both sanding and buffing because a sander rotates much faster than a buffer. There are combination sanding/buffers, that run at different speeds to accommodate both operations.

END OF WORK PACKAGE

PAINT FAILURES

SCOPE

This Work Package (WP) discusses troubleshooting techniques used for the most frequent causes of paint failure.

There is a cause for every paint failure, and in most instances, failure can be prevented by observing specific precautions and instructions. The weather, with its humidity, heat, cold, sudden rainstorms, etc., can damage a paint film, and for this reason, painters should take into consideration atmospheric conditions prior to painting.

CAUTION

Coatings should not be applied at temperatures below 50°F (10°C).

Alligatoring and Checking**Characteristics**

When a rupturing of the top paint coat causes surface to break up into irregular areas (separated by wide cracks in alligator-hide style), the condition is referred to as "alligatoring" or "checking." Alligatoring on a painted surface can be detected by appearance in top coat of small openings or ruptures which divide the surface into small irregular areas, leaving undercoat visible through breaks in top coat.

Probable Cause

Alligatoring is usually caused by too soft an undercoat or by applying a coat over an underlying coat which has not thoroughly dried.

Corrective Measures

Remove entire paint coat using a scraper or paint remover. Mild cases should be thoroughly wire brushed. Before repainting, clean surface after old paint has been removed.

Bleeding**Characteristics**

When color of a previous coat is absorbed into topcoat, the condition is called "bleeding".

Probable Causes

Bleeding is usually caused by partial solution of old pigment into new coat. Bleeding may also occur with asphalt and colored resins.

Corrective Measures

The corrective measures to be taken depend on severity of bleeding and quality of appearance required. If bleeding is not severe, and appearance is not important, apply another coat of paint after previous coat (in which bleeding occurred) has dried thoroughly. If this method fails to provide an acceptable finish, remove all paint coatings, clean surface thoroughly, and repaint.

Blistering**Characteristics**

Blistering is evidenced by blister like irregularities on film of a painted surface, with paint coat detached and raised from surface upon which it is applied.

Probable Causes

Blistering is the result of gases or liquids (usually water) forming under coating. The most common cause of blistering on wood surfaces is application of paint over a damp or wet surface. The breaking of blisters may result in a peeling of paint coat. Blistering is also caused by using a paint that is incompatible with that used in a previous coating.

Corrective Measures

Use a wire brush or scraper to remove all defective paint. Permit surface to dry thoroughly, and then repaint.

Blushing**Characteristics**

A surface on which blushing has occurred is characterized by a white discoloration in coating and sometimes by separation of ingredients from coating. Blushing most commonly occurs in nitrocellulose lacquers.

Probable Causes

Blushing may be caused by condensation of moisture on film or by improper composition of vehicle (pigment-carrying liquid portion of paint) or solvent.

Corrective Measures

Remove or sand film where blushing has occurred and repaint (after ensuring that surfaces are dry). Blushing on acrylic lacquer may be prevented by adding acrylic lacquer retarder to liquid lacquer.

Chalking**Characteristics**

Chalking can be detected by existence of dry, loose powder on paint film. Rain tends to wash this powder off of exterior surfaces.

Probable Causes

The chalking of a painted surface is governed partially by composition of paint. Chalking, loss of luster, and deterioration of surface film are also affected by atmospheric conditions. Paints low in binder content, or high in inert pigments, have a tendency toward early and excessive chalking.

Corrective Measures

A paint which chalks moderately affords a better repainting surface than one which does not chalk at all; however, if excessive chalking has taken place, remove all loose and powdery substance from surface with a wire brush and repaint.

Cracking, Flaking, Scaling, and Peeling**Characteristics**

Breaks which extend through paint film to bottom surface are called cracks. Cracking is usually followed by flaking, scaling, or peeling. Flaking is the dropping off of small pieces of paint coat. Scaling is an advanced form of flaking and is evidenced by larger flakes. Peeling is the curling and dropping off of relatively large pieces of paint film.

Probable Causes

Paints which become brittle when dried cannot contract or expand with moisture and temperature changes, and are very susceptible to cracking. Cracking may also be caused by too many coats being built up due to previous painting. Cracking advances to scaling and peeling as old paint, which has lost its elasticity and much of its adhesive grip, is pulled loose by surface tension of new paint film as it dries. Low grade paints usually lack elasticity because they are deficient in oil and contain too much inert material for extended exposure. Since flaking and scaling are usually preceded by cracking, their causes are much the same as for cracking. Scaling and peeling frequently occur when paint has been applied to unseasoned or damp lumber. Peeling may also occur around knots, and where cracks in paint permit water to get behind paint film.

Crawling or Creeping**Characteristics**

Crawling or creeping of paint is noted by little drops (or islands) which form on paint film.

Probable Cause

Crawling often occurs when varnish or enamel is applied on an oily or greasy surface. Painting over a very smooth surface will sometimes cause crawling.

Corrective Measures

Remove little islands of paint which have formed on film by sanding them, and wash off any grease or oil which may be underneath. If a glossy coat has been applied over another glossy coat, remove both coats using varnish and paint remover. Apply a prime coat without gloss before applying a high gloss topcoat.

Dulling**Characteristics**

Dulling is characterized by loss of gloss which should be present in a high gloss varnish, paint, or enamel film after it has dried.

Probable Cause

Dulling may be caused by action of gases, inferior products, use of very old stock, or use of too much turpentine or thinner.

Corrective Measures

Remove dulled coat, or sand it down with fine sandpaper, and apply a varnish, paint or enamel of known good quality.

Mildewing**Characteristics**

Mildew is a fungus frequently found on exposed surfaces in warm, damp climates, particularly on soft paint films.

Probable Causes

Paint film that has become sticky or tacky attracts windblown spores and decayed and dried vegetation to its surface. The oil in paint sometimes becomes infested, and breeding of mildew spores takes place.

Corrective Measures

To prevent recurrence of mildew, old coat of paint should be removed and a new coat of hard-drying paint applied. A fungus growth can be partially removed by scrubbing affected surface with a solution of trisodium phosphate and water. The surface should then be rinsed with clear water and allowed to dry. The use of less paint and more thinner is advised in environments where mildew is a common occurrence.

Streaking and Lumping**Characteristics**

Streaks or lumps on painted wood surfaces are caused by resin and pitch exuding from knots and unseasoned lumber.

Probable Causes

This condition is caused by painting over unseasoned lumber and by painting over knots or resinous streaks which have not been properly treated before painting. On metal, it is an indication that paint has been applied incorrectly.

Corrective Measures

Apply shellac, varnish, or aluminum paint to wood knots before painting. Do not paint unseasoned wood. For metal, apply paint with a spray gun, holding gun level so that an even coat is applied.

Running and Sagging**Characteristics**

An effect of ripples or irregularities in a film of paint, varnish, or lacquer is known as runs or sags.

Probable Causes

Runs or sags are usually produced by application of paint, varnish, or lacquer which has been thinned excessively, or by application of too much material. It is usually evident on a sloping or vertical surface. Other causes are incomplete brushing or use of a stiff brush.

Corrective Measures

Sand surface until runs or sags have been removed, then recoat with material of correct consistency, taking care not to apply excessive amounts. Use a flexible brush for this operation.

Slow Drying**Characteristics**

Although time required for drying is dependent upon type of paint, enamel, varnish, or lacquer used, certain weather conditions may prolong drying period. Paints which, under normal drying conditions, are tacky or sticky for long periods (12 hours or longer) are likely to attract dust and dirt, to promote mildew, or to develop checking or alligatoring.

Probable Causes

Cold weather retards drying. Drying agents also may lose their effectiveness in prepared paints that are dark in color. The use of old thinner, or use of inferior driers and thinners, are other factors frequently contributing to slow drying of paint films.

Corrective Measures

Do not paint when temperature is below 50°F (10°C). A standard procedure is to paint a test area and let it dry overnight before adding additional drier to paint. This is done to assure a correct drying period. In cold weather, apply a thin uniform film on a dry surface.

Spotting**Characteristics**

The appearance of discolored spots on a painted surface is known as spotting.

Probable Causes

Color changes and loss of gloss in irregular patches may be caused by spots in the surface which absorb oil from paint unevenly. This may be the result of too few coats, or lack of controlled penetration of paint, and may occur on new items which have been given only two coats, or an old item painted with just one coat. In white paints, this is accompanied by the loss of gloss. Colored paints usually appear to fade when oil is absorbed unevenly. Spots are sometimes caused by nail heads which rust. Splashes of liquid on a freshly varnished surface will cause spotting, and rain or hail on a freshly painted surface will also leave spots.

Corrective Measures

Apply an additional coat of paint. Apply paint during dry weather. The use of paint containing zinc oxide is effective in minimizing spotting on older items. In cases of spotting due to rain or sandstorms, sand off rough spots before repainting.

Sweating**Characteristics**

The reappearance of luster on a varnished surface which has been rubbed to a dull finish is known as sweating.

Probable Causes

Sweating of a varnished surface is usually caused by inadequate rubbing to attain a dull finish or application of a finish coat before undercoats have thoroughly hardened.

Corrective Measures

After surface is thoroughly hardened, rub down finish thoroughly and then apply another finish coat.

Wrinkling**Characteristics**

Wrinkling of a paint coat is evidenced by paint film gathering in small wrinkles.

Probable Causes

Wrinkling may be caused by application of an excessively thick coat, or by a failure to brush out paint properly. Wrinkling may also be caused by too much drier in paint. Paints which have been excessively thinned with oil and applied thickly are also subject to wrinkling.

Corrective Measures

Sand off wrinkles with rough sandpaper and paint with properly thinned paint which does not have an excessive amount of drier or oil in it. In cases of excessive wrinkling, strip off old coats and repaint. Wrinkling in acrylic lacquer may be prevented by adding acrylic lacquer retarder.

END OF WORK PACKAGE

CHAPTER 6
LETTERING AND SIGN PAINTING
FOR
PAINTING INSTRUCTIONS FOR
ARMY MATERIEL

LETTERING AND SIGN PAINTING

SCOPE

The directions given in this Work Package (WP) are designed to acquaint the painter with basic principles of lettering and sign painting.

LETTERING STYLE

The lettering style suitable for all Military requirements is known as the Vertical Gothic Style, as illustrated in Figure 16-1. There will be times when stencils and decals are not available, requiring the soldier to utilize hand lettering. The types of brushes required, and lettering and painting techniques used, are described in the following paragraphs.

BRUSHES

Rough Surfaces

Painting brick, concrete, stucco, rough plaster, and boards that have been painted before will require a flat bristle brush. The size depends upon width of letter. Brushes for these surfaces are classified as fitches, angular fitches, and cutters.

Smooth Surfaces

Painting metal, glass, vehicles, boards, hardboard, and cardboard, will require a softer, flat bristle, artist-type brush, or an oval wash brush, to obtain a finer degree of finish. These brushes are classified as single stroke, lettering brushes, and come in a variety of soft bristle combinations. For beginner's use, a flat oxhair and sable combination is suggested. This type of lettering brush has a knifelike precision edge and will hold a large load of paint, which feeds evenly and accurately to surface; it is also easy to control.

LETTERING TECHNIQUE

Preparation of Brush

Dip brush into paint until all bristles are immersed. Raise brush straight up until all excess paint drips from it. Stroke brush back and forth on a smooth, flat surface in razor strap style until paint is worked well up into bristles, and until end of bristles form a sharp chisel-like edge as shown in Figure 16-2. This makes it possible to form a sharp, uniform stroke.

LETTERING TECHNIQUE (continued)

Basic Strokes

For lettering, an oval wash brush should be used because of its rounded end. Three basic strokes form the basis of all Vertical Gothic Lettering. The three basic strokes are: straight (vertical, horizontal, slant), left curve, and right curve. The basic principles of these strokes are demonstrated in Figure 16-3. To differentiate still further, basic strokes can be separated into nine subdivisions: vertical, horizontal, left slant, right slant, left curve, right curve, top curve, bottom curve, and "S", as shown in Figure 16-3.

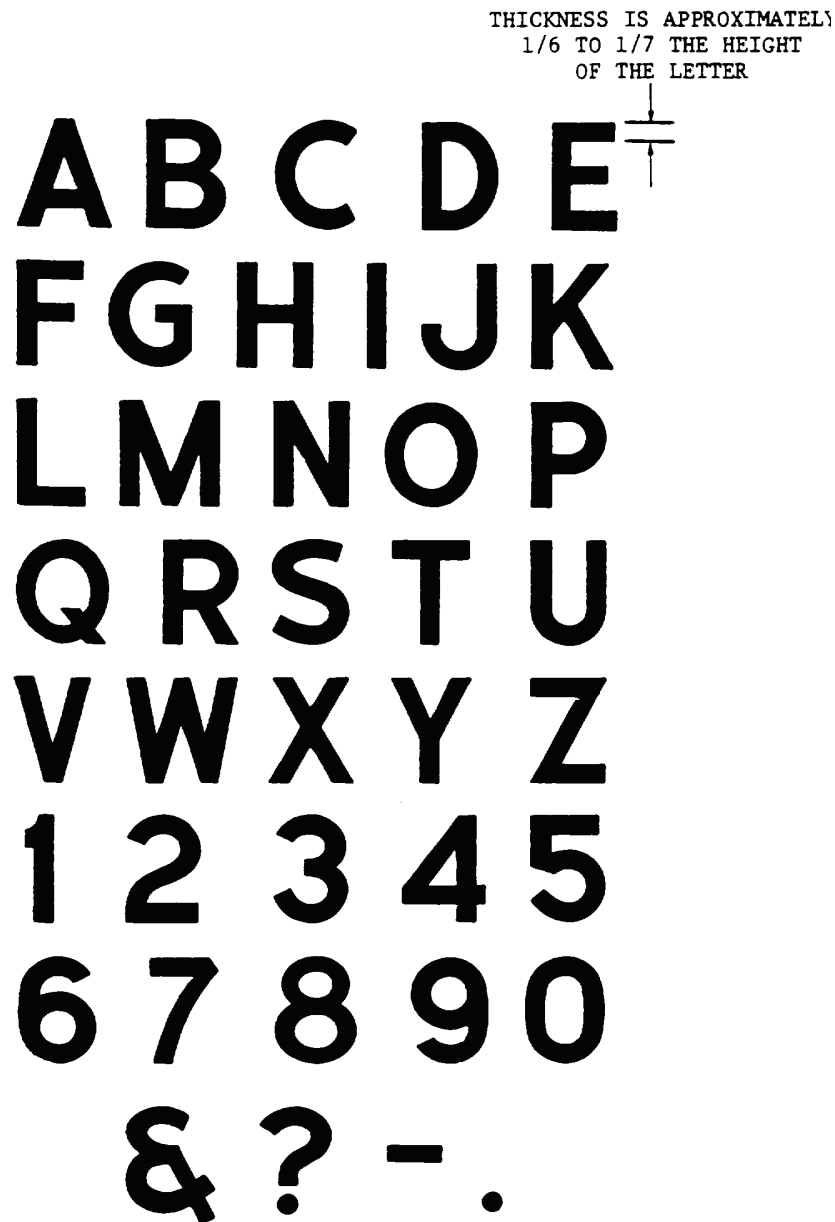
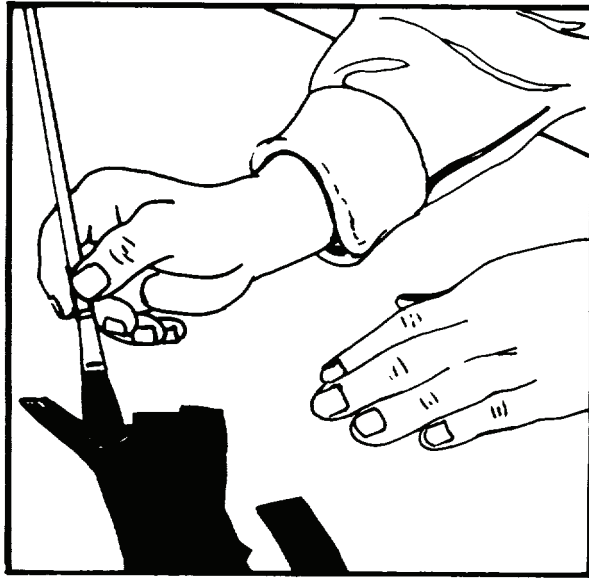
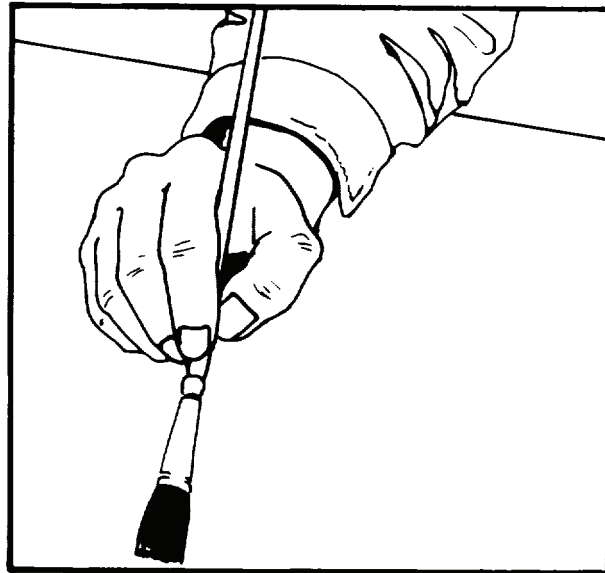

Figure 16-1. Lettering and Stencil Alphabet

LETTERING TECHNIQUE (continued)



A.



B.

Figure 16-2. Brush Preparation for Lettering

LETTERING TECHNIQUE (continued)

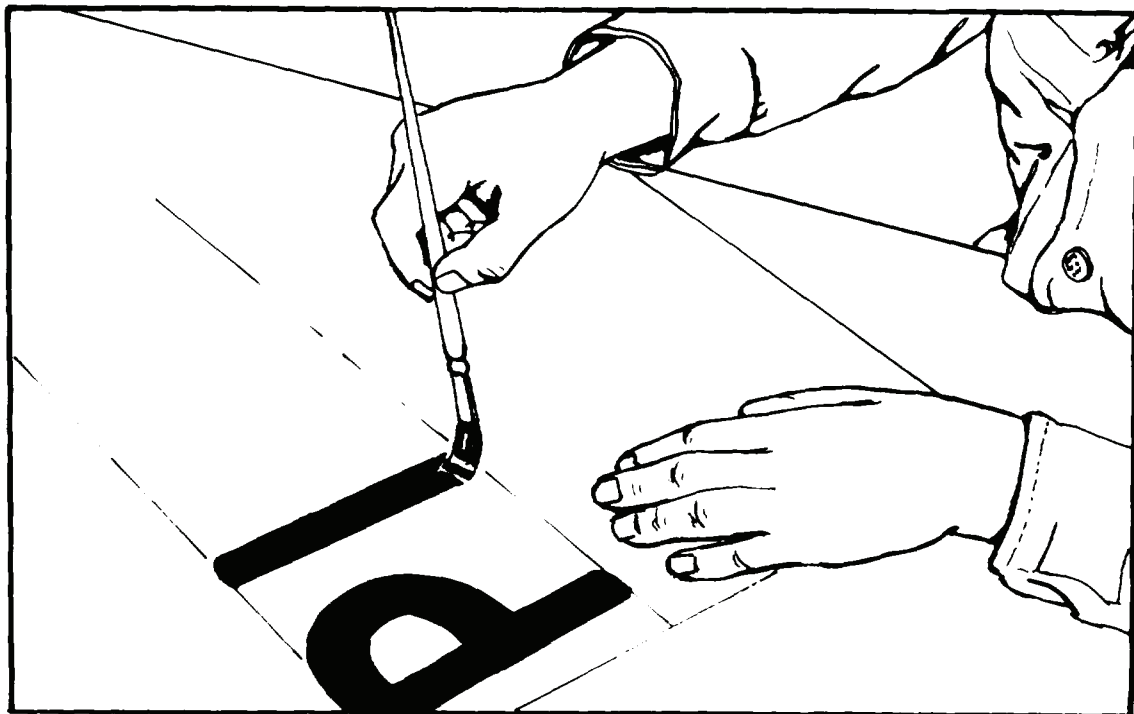
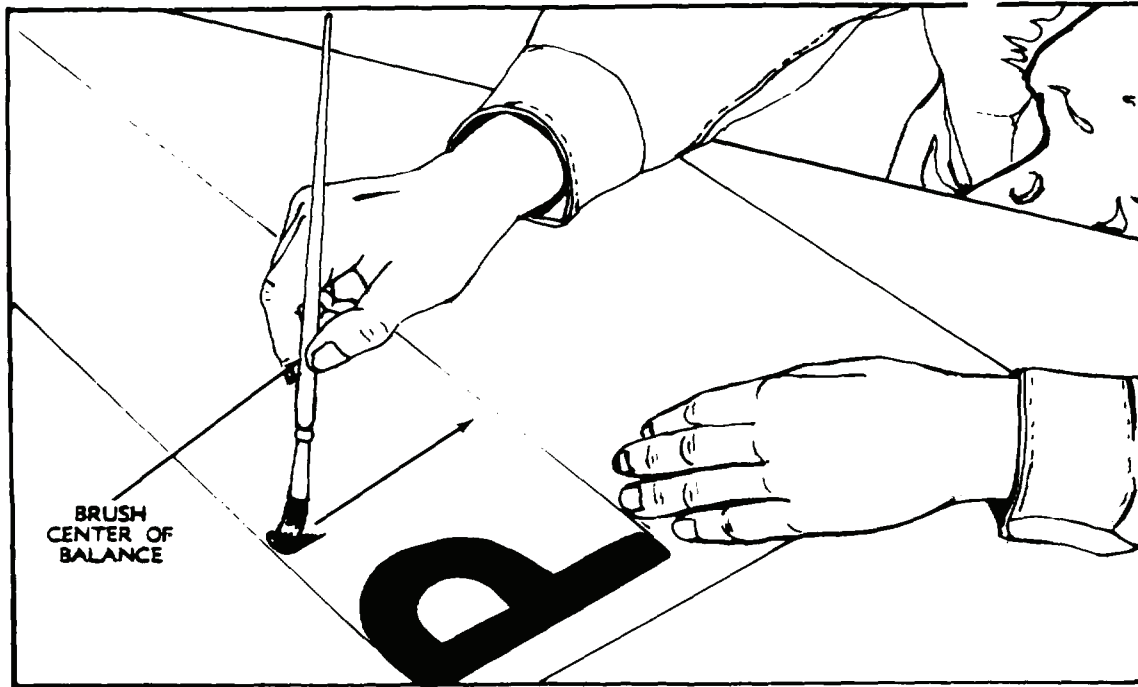
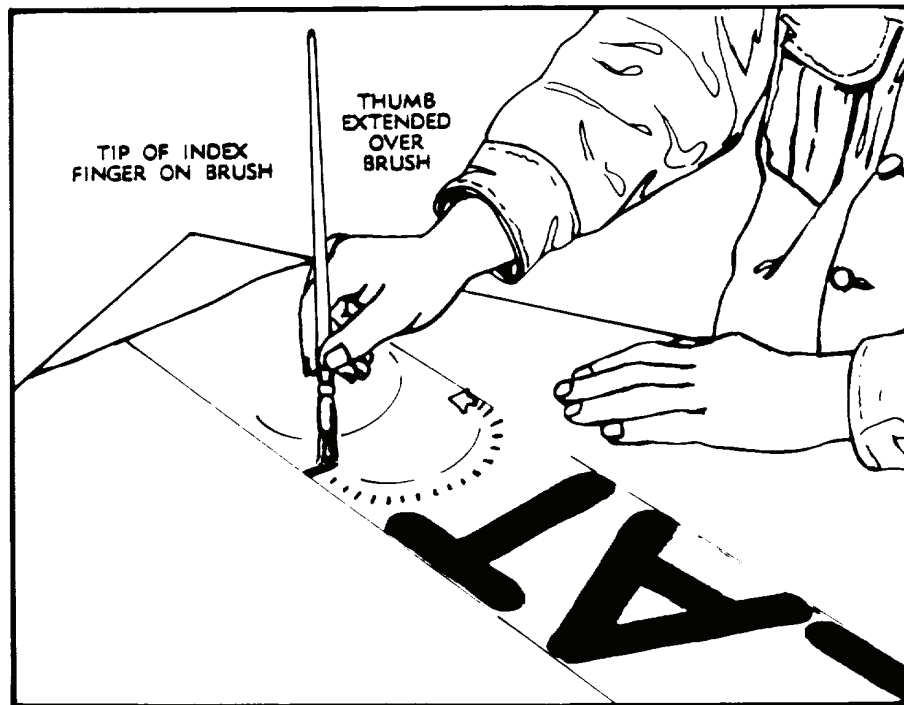
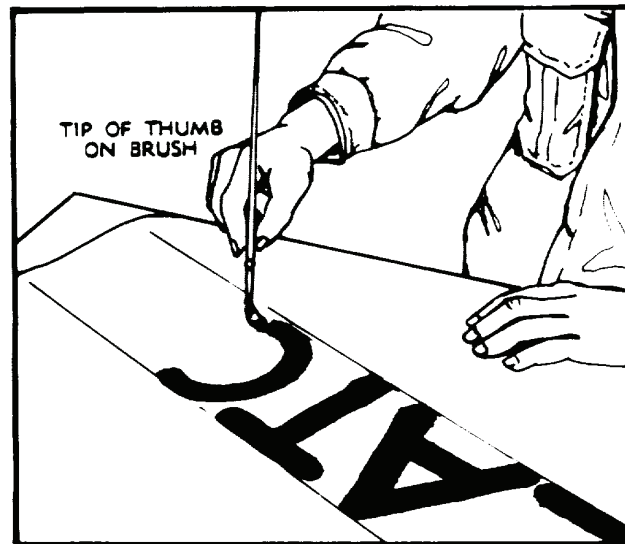

Figure 16-3. Lettering Techniques (Sheet 1 of 3)

LETTERING TECHNIQUE (continued)



A. LETTERING—METHOD OF HOLDING BRUSH AT START OF LEFT CURVED STROKE.



B. LETTERING—POSITION OF BRUSH AT END OF LEFT CURVED STROKE.

Figure 16-3. Lettering Techniques (Sheet 2 of 3)

LETTERING TECHNIQUE (continued)

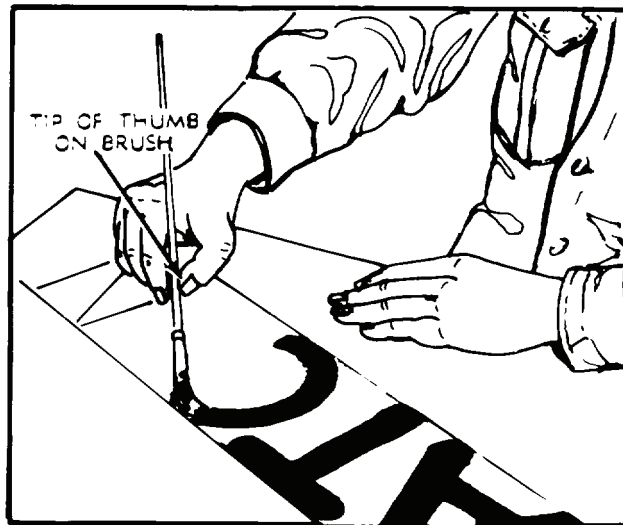

C. LETTERING—METHOD OF HOLDING BRUSH AT START OF RIGHT CURVED STROKE.

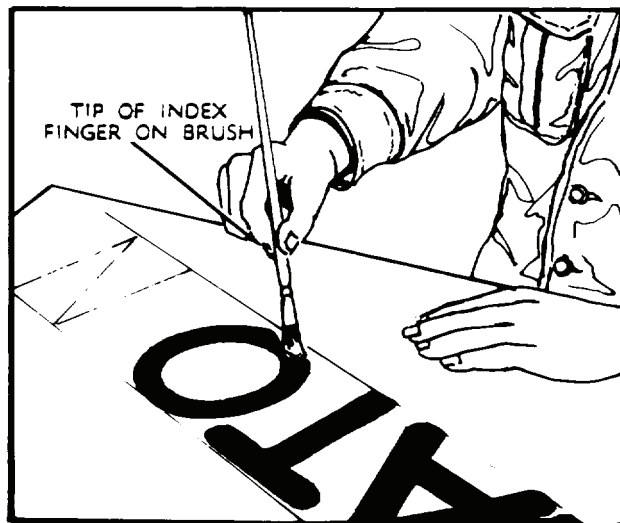

D. LETTERING—POSITION OF BRUSH AT END OF RIGHT CURVED STROKE.

Figure 16-3. Lettering Techniques (Sheet 3 of 3)

LETTERING TECHNIQUE (continued)

Direction of Brush Strokes

The appearance of a hand-drawn letter depends, to a very considerable degree, upon direction given to each brush stroke. It is therefore important to closely follow standard directions shown in Figure 16-4, using oval wash brush.

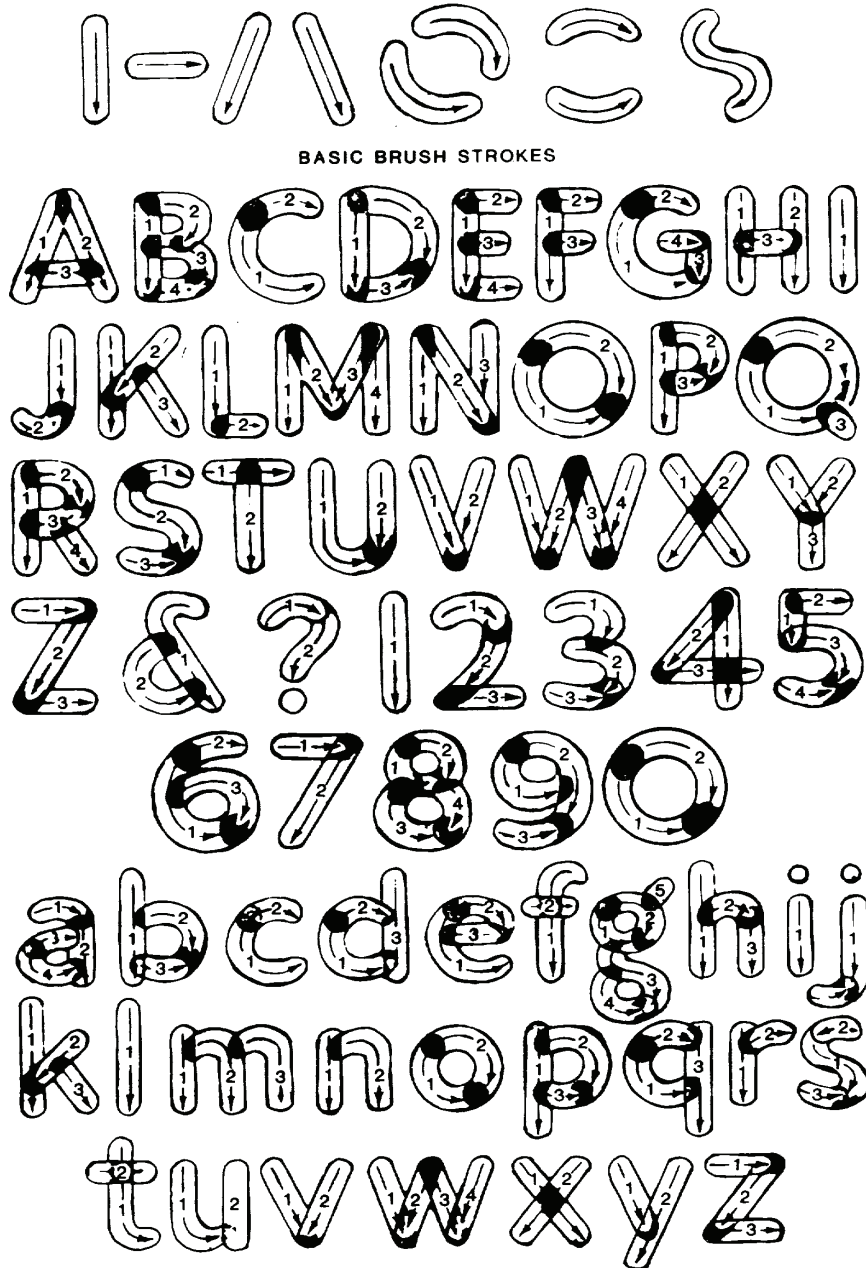

Figure 16-4. Brush Strokes for Lettering

LETTERING TECHNIQUE (continued)

Right and Wrong Ways of Lettering

Avoid mistakes indicated in Figure 16-5, and follow right methods as shown.

Spacing and Balance

It is particularly important for a less experienced sign painter to pencil-in letters upon working surface before painting, making sure that they are accurately spaced and balanced and of uniform size and relationship. It may be necessary to letter under difficult conditions, at times, and with limited materials. In this event, the following method should be used.

HAND SIGN PAINTING

Identify area to be marked and clean it of dirt, grease, and base paint. Using chalk, draw parallel lines the width of desired letters and numbers, as shown in Figure 16-5.

Using techniques described above, draw letters and numbers, with chalk, between parallel lines in preparation for painting.

Paint letters and numbers using proper paint brush and paint.

Allow paint to dry before touching. Time for drying is dependent upon kind of paint used, temperature, and thickness of paint film. Protect markings from dust and dirt until dry.

Once thoroughly dry, use a cloth and rub off chalk guidelines.

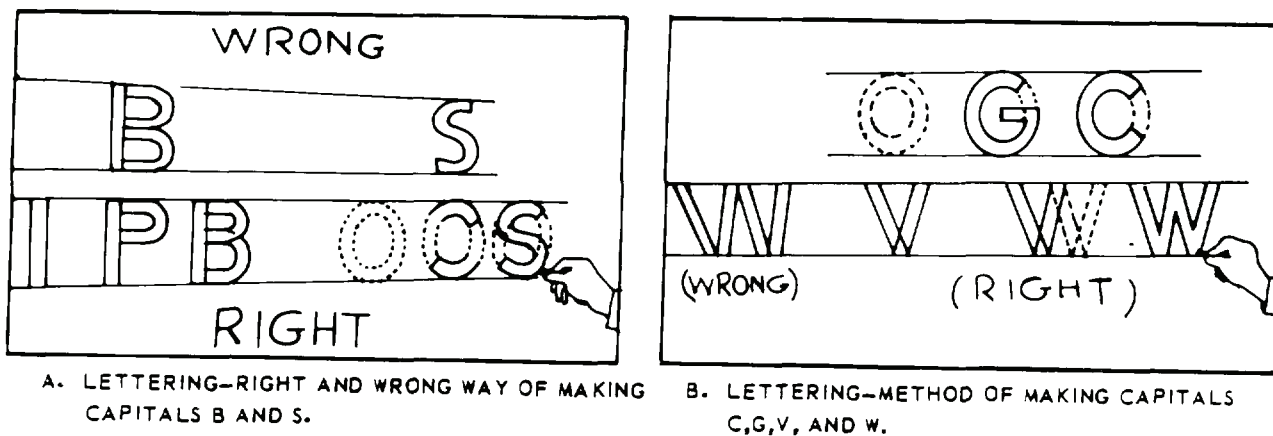

Figure 16-5. Lettering Method

END OF WORK PACKAGE

STENCIL AND PAINT MARKING

SCOPE

This Work Package (WP) details stenciling techniques used on Army materiel. Stencils enable untrained personnel to apply lettering and designs to materiel quickly and efficiently. A stencil is a paper or metal pattern which has letters or design cutout, so that when stencil is held in position over a surface and paint is applied to cutout portions, lettering or design will be accurately reproduced. When a large number of signs, identification marks, or designs are to be reproduced, time is saved by using a stencil.

STENCILING TECHNIQUES

This method of painting requires the use of gummed-back (pressure-sensitive) paper stencil.

Paper stencils are available as individual letters, numerals, and legends of various sizes.

The surface to which a marking is to be applied must have all oil, dirt, and grease removed and must be dry to prevent contamination of stencil adhesive and marking paint. Use MIL-D-16791, Type I, Detergent, General Purpose (Liquid, Nonionic), or another approved cleaning solution for this purpose.

Paper Stencil Application Techniques.

- Identify area to be marked. Draw a straight guideline for proper positioning of letters, numbers, or legend.
- Peel off gum-protector paper from paper stencil; avoid touching adhesive.
- Handle stencil with caution to avoid wrinkling or distorting characters, and apply to proper location on vehicle or equipment.
- After fixing stencil in place, remove webs from letters and numerals so that finished marking appears with unbroken lines.
- Mask areas between, above, and below stencils using masking tapes and paper to prevent overpainting.
- Apply paint to stenciled area by spraying or brushing; spraying is preferred. Use Chemical Agent Resistant Coating (CARC) lusterless Black 37030 or 37038, or Green 383 (34094) for applications requiring chemical agent resistant systems.
- A few minutes after painting, remove stencils. This must be done with care to avoid smudging marking or adjacent surface area.

STENCILING TECHNIQUES (continued)

- Do not touch painted marking until thoroughly dry; drying time is dependent upon temperature, type of paint, method of application, and thickness of paint film. Take care to protect marking from dust and dirt during drying period.
- Carefully clean all paint overspray, smudges, and residue from area. Use mineral spirits paint thinner and a cloth. This must be done with care; avoid contact of marking with thinner.

END OF WORK PACKAGE

PRESSURE SENSITIVE ADHESIVE VINYL MARKERS (DECALS)

SCOPE

This Work Package (WP) describes application techniques used for pressure sensitive adhesive vinyl markers. These markers are available as die-cut letters, numerals, and legends in various sizes. Vinyl markers are applied to surface without water or other solvent to activate adhesive. They are mounted on a protective paper lining that is removable without use of a solvent. The marker face is covered by a translucent application tape which is removed after marker application. Markers are resistant to grease, oil, water, salt spray, gasoline, and aromatic fuels. Cleaning of markers requires only water and soap or detergent.

APPLICATION TECHNIQUES

The surface on which marker is to be applied must be clean and dry. All oil, grease, and dirt must be removed by washing with liquid detergent cleaner or an approved cleaning solution to prevent contamination of adhesive. Allow sufficient time for cleaning agent to evaporate. Vinyl markers cannot be adequately applied to extremely irregular or rough surfaces. Complete contact of marker to surface is necessary for proper adhesion. Old markers must be removed completely prior to applying a new marker.

Old pressure sensitive vinyl markers may be removed by soaking markers with a rag or sponge, dipped in an approved adhesive softening mixture. The marker may then be removed with a putty knife or scraper without damaging the materiel surface.

Alternate but less effective methods of removing markers involve use of common paint removers or a sharp bladed instrument. Avoid materiel surface damage and self-inflicted personal injury.

CAUTION

The vinyl marker cannot satisfactorily be removed by power sanding or abrasion. These methods will damage the materiel surface, necessitating refinishing.

Application of vinyl markers should be made at moderate temperatures above 40°F (4.44°C), but may be made at lower temperatures if surface is prepiped with technical isopropyl alcohol. If surface temperature is warm or hot, ensure that application is exact at first contact since decal will stick quickly.

Sealing of markers or their edges with varnish or other sealant is neither required nor recommended.

Legend Marker Application. Each legend marker is prespaced and precentered on application tape and backed with a protective liner over pressure sensitive adhesive.

1. Mark a straight horizontal guideline on materiel surface in appropriate location. This guideline will be used for properly positioning legend.

APPLICATION TECHNIQUES (continued)

2. Place legend on a flat surface with translucent application tape side down, and carefully remove protective liner. Avoid handling adhesive on legend marker.

Legend Marker Application (continued)

3. Position legend to guideline on materiel. Press one edge down while holding the rest of the legend taut and slightly away from surface. Refer to Figure 18-1A.
4. Roll legend down firmly with a roller or applicator to remove any trapped air bubbles or wrinkles. Refer to Figure 18-1B.
5. Starting at one corner of marker, remove application tape by carefully peeling it back flat against itself. Refer to Figure 18-1C.
6. Roll legend again to ensure complete and firm adhesion.

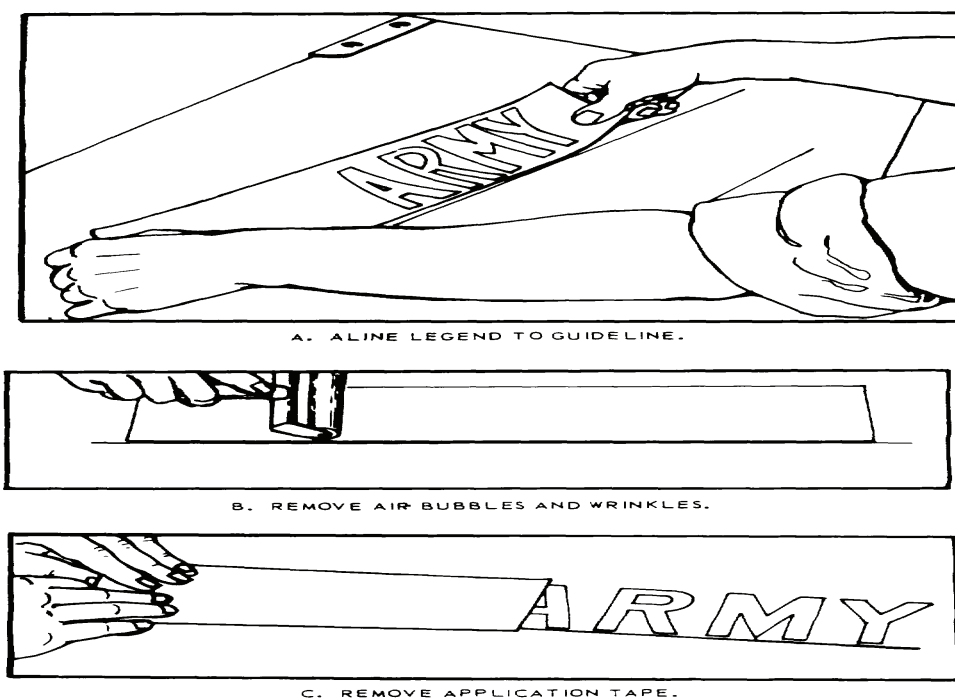
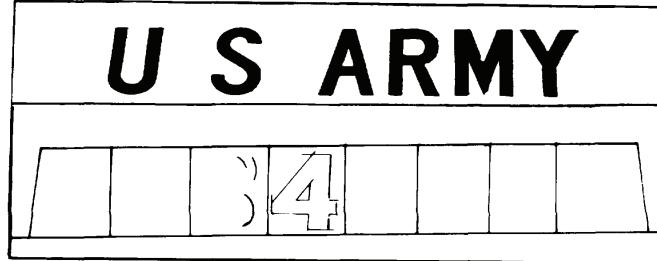

Figure 18-1. Applying Adhesive Vinyl Markers (Decals)

Legend Marker Application (continued)

Character (Letter or Numeral) Marker Application. Each character (letter or numeral) is precentered on application tape and backed with a protective liner over pressure sensitive adhesive.

1. Mark a straight horizontal guideline on materiel surface in designated location. This guideline will be used for proper alignment of characters.
2. Place first character on a flat surface with translucent application tape side down and carefully remove protective liner. Avoid handling adhesive on character.
3. Position character to guideline on materiel. Press one edge down while holding rest of character taut and slightly away from surface.
4. Roll character down firmly with a roller or applicator to remove any trapped air bubbles or wrinkles. Do not remove application tape at this time.
5. Repeat steps (2), (3), and (4) above, in order, for each remaining character in desired marking. Place left edge of application tape against right edge of preceding application tape.
6. When entire marking is properly positioned and applied, remove application tape. Start at a corner and carefully peel each application tape back, flat against itself. Refer to Figure 18-2B.
7. Roll characters again to ensure firm adhesion.



A. CHARACTERS SPACED PROPERLY.

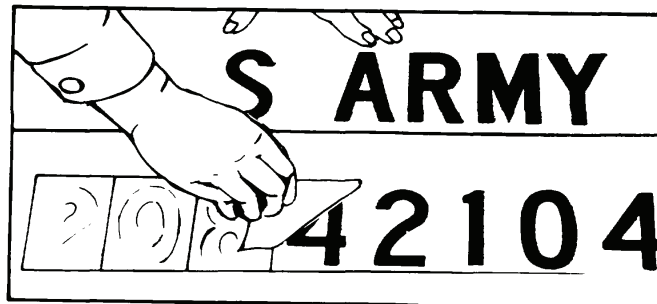

B. REMOVE EACH TAPE SEPARATELY.

Figure 18-2. Letter or Numeral Application

VEHICLE NATIONAL SYMBOL MARKINGS

This paragraph is concerned with application of the National Symbol (star) to vehicle surfaces. This method applies to National Symbols made of vinyl material.

National Symbol markings are available in various sizes from six to 36 inches (measurement between opposite points).

Vinyl material National Symbol is applied directly to equipment surface without use of water or other solvent to activate pressure sensitive adhesive. The symbol is mounted on a protective liner with symbol face covered by a premask tape.

Vehicle or equipment surface must be cleaned of dirt, grease, dust, and loose paint prior to application.

Application

1. Place symbol on a flat surface, face up. Cover one point of symbol with a small piece of masking tape, rubbing tape down firmly onto symbol.
2. Hold symbol by tape, in one hand. Begin separation of protective paper liner from adhesive side of symbol.
3. Place symbol on a flat surface, face down. Carefully continue pulling paper liner from one point of symbol past horizontal base of point. Fold liner as it is freed from symbol.
4. Position symbol on equipment surface. Apply exposed symbol tip to surface while holding the rest of symbol taut and slightly away from surface. Apply exposed portion of symbol while rolling and pressing material to remove wrinkles and air bubbles.
5. Continue removing paper liner as stated in steps (3) and (4) above, rolling and pressing unapplied portion of symbol to surface until entire marking is applied.
6. Roll entire marking again, with particular attention to edges, to ensure firm and complete adhesion.
7. Remove premask tape on face of symbol by pulling carefully on masking tape piece (applied in step (1) above), folding premask tape back against itself. Carefully pull back to opposite edge of symbol. With this operation, protective premask tape will tear. The remaining pieces may be removed by pulling them, folded back, from center of symbol to remaining symbol points. Roll marking again with particular attention to edges.
8. Any remaining small air bubbles may be punctured with a pin and air may be worked out with a finger.

END OF WORK PACKAGE

POUNCING

SCOPE

This Work Package (WP) discusses the pouncing method used when it is necessary to make a quantity of the same legends, signs, identification marks, or designs, and a stencil legend is not already available. Pouncing is term applied to use of a perforated pattern in transferring outline of a legend, sign, or design to be painted on a painting surface.

Pouncing should also be used when more accurate lettering and designs are desired than can be attained by stenciling letters individually, and particularly when working over larger areas.

EQUIPMENT

The following equipment and materials are needed to prepare a pouncing pattern:

- Thin, durable paper (large enough to cover lettering or design).
- Light cardboard.
- A pouncing wheel.
- Dry color, powdered chalk, or other powder.
- Flint sandpaper, grade 2/0.
- Masking tape.
- A thin cloth.

PROCEDURE

1. Pencil-in (draw) letters, numerals, or design on a plain sheet of paper.
2. Place penciled-in paper on top of cardboard or other material which can be easily perforated by a pouncing wheel. Then, by using a pouncing wheel, perforate outline of markings which have been penciled-in. Refer to Figure 19-1A. If a pouncing wheel is not available, use a large needle or other sharp pointed object to perforate outline.
3. Turn pattern over and use flint sandpaper, grade 2/0, to sand off all rough edges of perforations. Refer to Figure 19-1B.
4. Prepare a pouncing bag by placing dry color, powdered chalk, or any other available powder in a thin cloth. Tie cloth so it forms a bag with powder inside.

PROCEDURE (continued)

5. Place pattern in desired position on surface to be painted. Secure it in position with masking tape, and then gently tap all perforations with pouncing bag until powder is worked through perforations and onto painting surface. Refer to Figure 19-1C.

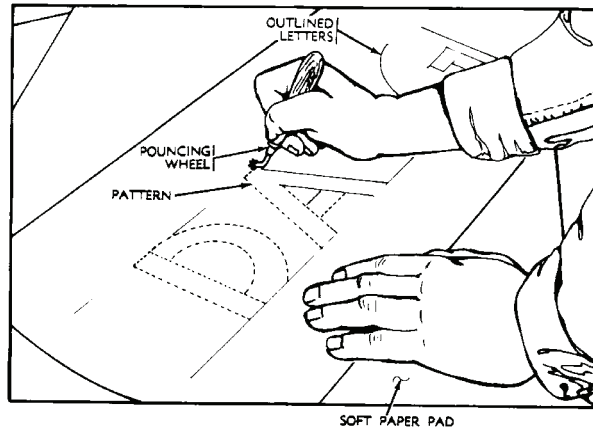

A. PERFORATING A PATTERN FOR POUNCING

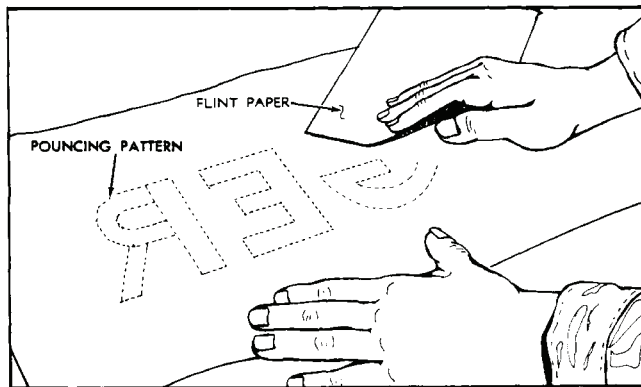

B. SANDING THE BACK OF A POUNCING PATTERN.

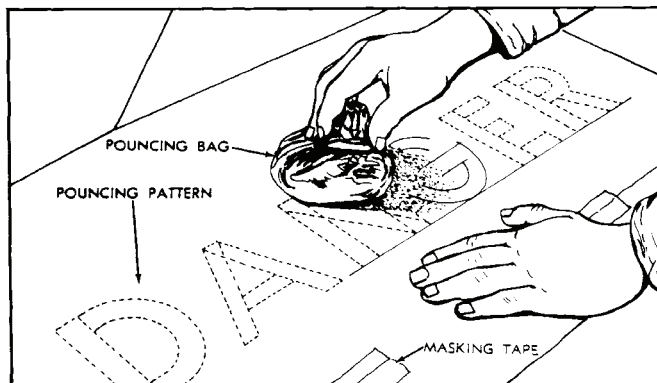

C. POUNCING A LETTERING PATTERN.

Figure 19-1. Pouncing Techniques (Sheet 1 of 2)

PROCEDURE (continued)

6. Remove pattern, taking care not to smudge perforation dots on painting surface. Refer to Figure 19-1D.
7. Select proper paint brush, and paint in legend or design, taking care not to go outside dotted pattern. Refer to Figure 19-1E.

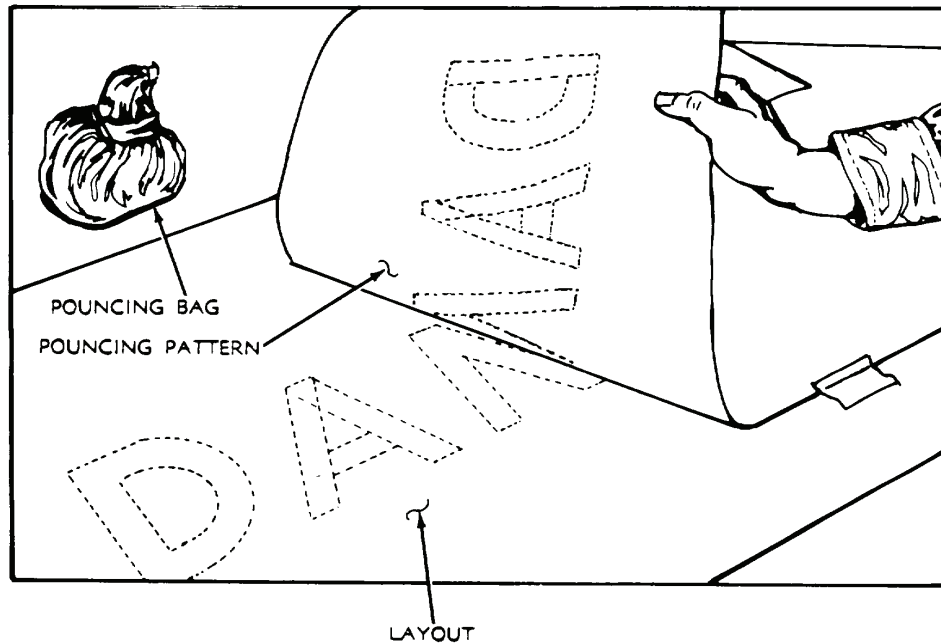

D. REMOVING THE PATTERN. POUNCING PATTERN TRANSFERRED TO SURFACE TO BE PAINTED.

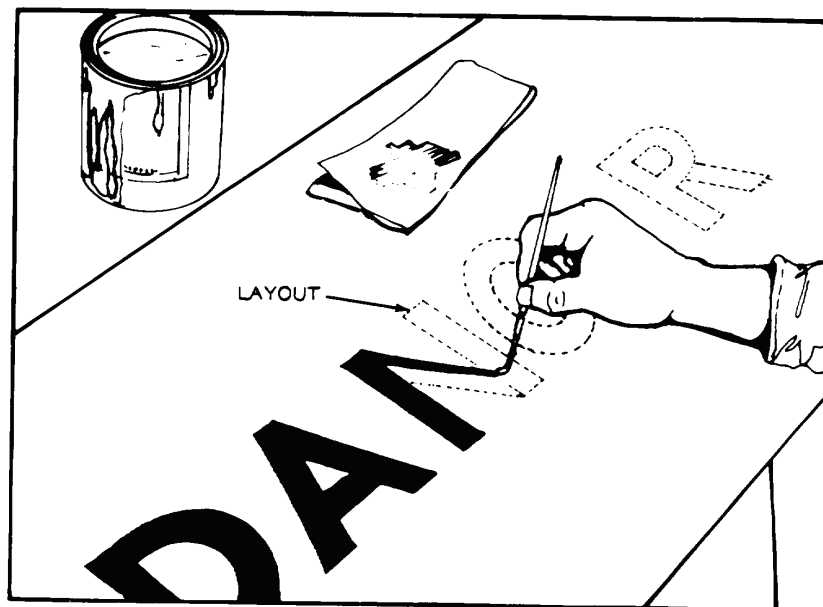

E. PAINTING IN A POUNCED SIGN PATTERN

Figure 19-1. Pouncing Techniques (Sheet 2 of 2)

PROCEDURE (continued)

8. Allow paint sufficient time to dry before touching it. Drying time is dependent upon kind of paint used, temperature, and thickness of paint film. Protect markings from dust and dirt until dry.
9. Once paint is thoroughly dry, use a cloth and rub off any leftover powder residue.

END OF WORK PACKAGE

**CHAPTER 7
SUPPORT DATA
FOR
PAINTING INSTRUCTIONS FOR
ARMY MATERIEL**

REFERENCES

GENERAL

This Work Package (WP) lists all forms, field manuals, technical bulletins, technical manuals, specifications and standards, and other publications referenced in this Technical Manual (TM).

PUBLICATION INDEX

DA Pam 25-30, Consolidated Index of Army Publications and Blank Forms.

FORMS

Refer to DA Pam 750-8, The Army Maintenance Management System (TAMMS) Users Manual.

Equipment Control Record DA Form 2408-9
 Material Safety Data Sheets MSDS
 Product Quality Deficiency Report SF 368
 Recommended Changes to Publications and Blank Forms DA Form 2028

FIELD MANUALS

First Aid FM 4-25.11

TECHNICAL BULLETINS

Color, Marking and Camouflage Painting of Military Vehicles, Construction Equipment, and Materials Handling Equipment TB 43-0209
 Color, Marking and Camouflage Patterns Used on Military Equipment TB 43-0147
 Corrosion Prevention and Control Including Rust proofing Procedures for Tactical Vehicles and Trailers TB 43-0213
 Occupational and Environmental Health Respiratory Protection Program TB MED 502
 Guidelines For Controlling Health Hazards In Printing Operations TB MED 514
 Painting of Watercraft TB 43-0144

TECHNICAL MANUALS

Steel Structures Painting Council Manual, Commercial Blast Cleaning SSPC-SP6
 Steel Structures Painting Council Manual, Near-White Blast CleaningSSPC-SP-10

REFERENCES (continued)

0020 00

Technical Manuals (continued)

Steel Structures Painting Council Manual, White Metal Blast Cleaning SSPC-SP-5

TM SPECIFICATIONS AND STANDARDS

Acetone ASTM D329

Alcohol, Dehydrated, USP..... A-A-51693

Anodic Coatings for Aluminum and Aluminum Alloys MIL-A-8625

Chemical Agent Resistant Coating (CARC) System Application Procedures and
Quality Control Inspection MIL-DTL-53072

Chemical Conversion Coatings and Pretreatments for Ferrous Surfaces
(Base for Organic Coatings)..... TT-C-490

Chemical Conversion Coatings on Aluminum and Aluminum Alloys..... MIL-DTL-5541

Coating, Aliphatic Polyurethane, Single Component, Chemical Agent Resistant MIL-DTL-53039

Coating Compound, Metal Pretreatment, Resin-Acid (ASG).....MIL-C-8514

Coating, Epoxy, High-Solids.....MIL-PRF-22750

Coating, Water Dispersible Aliphatic Polyurethane, Chemical Agent Resistant..... MIL-DTL-64159

Degreasing Solvent MIL-PRF-680

Detergents, General Purpose (Liquid, Nonionic).....MIL-D-16791

Finishes for Ground Based Electronic EquipmentMIL-DTL-14072

Finishing of Metal and Wood Surfaces MIL-STD-171

Magnesium Alloy, Processes for Pretreatment and Prevention of Corrosion On..... SAE-AMS-M-3171

Marking Materials and Markers, Adhesive, Elastomeric, Pigmented Legends MIL-M-43719

Paint, Heat Resisting (for Steel Surfaces) MIL-P-14105

Primer, Cathodic Electrodeposition, Chemical Agent Resistant..... MIL-P-53084

Primer Coating: Epoxy, Waterborne..... MIL-PRF-85582

Primer Coating, Epoxy, Water Reducible, Lead and Chromate Free..... MIL-DTL-0053030

Primer, Epoxy Coating, Corrosion Inhibiting, Lead and Chromate Free.....MIL-DTL-0053022

REFERENCES (continued)

0020 00

SPECIFICATIONS AND STANDARDS (continued)

Primer, (Wash), Pretreatment (Formula No.117 for Metals) (Metric) DOD-P-15328

Safety and Health Regulations for Construction29 CFR Part 1926

Sealing Compound, Adhesive: Curing (Polysulfide Base) A-A-59293

Color and Marking of Army Materiel MIL-HDBK-1473

Thinner, Aircraft Coating MIL-T-81772

Coating Compound, Nonslip (For Walkways) A-A-59166

OTHER PUBLICATIONS

Army Materiel Maintenance PolicyAR 750-1

Management Acquisition and use of Motor VehiclesAR 58-1

National Electrical Code NFPA70

Occupational Safety & Health Administration (OSHA) Occupational Safety and Health
Standards
..... CFR 1910

Preventive Medicine.....AR 40-5

Army Facilities Management AR 420-1

END OF WORK PACKAGE

NATIONAL STOCK NUMBER TABLES

SCOPE

This Work Package (WP) contains tables of National Stock Numbers (NSN's) for various colors and sizes of coatings. It does not cover all coatings. However, most Chemical Agent Resistant Coatings (CARC) are covered. Also covered are primers, paint remover, and thinner. Table 21-1 lists what each table covers.

Table 21-1. NSN Tables

Table Number	Title
21-1	Cleaners, Liquid detergent MIL-D-16791, Solvent Degreasing, MIL-PRF-680
21-2	Coating, Aliphatic Polyurethane, Single Component, Chemical Agent Resistant, MIL-DTL-53039
21-3	Coating, Water Dispersible Aliphatic Polyurethane, Chemical Agent Resistant, MIL-DTL-64159, Type I and Type II
21-4	Coating, Epoxy, High-Solids, MIL-PRF-22750
21-5	Non-CARC Coatings, MIL-P-14105
21-6	Primers, MIL-DTL-0053022, MIL-DTL-0053030, and MIL-PRF-85582
21-7	Primer (Wash) Pretreatment (Formula No. 117 for Metals) (Metric), DOD-P-15328
21-8	Acetone, Technical, ASTM D329
21-9	Thinner, Aircraft Coating, MIL-T-81722
21-10	WD CARC Topcoat, Aerosol Spray, Type II
21-11	WD CARC Topcoat, Brush-top Applicator, Type II
21-12	WD CARC Topcoat, Roller-top Applicator, Type II

Table 21-1. Cleaners, Solvent Degreasing MIL-PRF-680, Liquid Detergent MIL-D-16791

MILSPEC	NSN	PRODUCT DESCRIPTION
MIL-PRF-680	6850-014722717	CLEANING COMPOUND,SOLVENT
MIL-PRF-680	6850-014742321	CLEANING COMPOUND,SOLVENT
MIL-PRF-680	6850-014742318	CLEANING COMPOUND,SOLVENT
MIL-PRF-680	6850-014722723	CLEANING COMPOUND,SOLVENT
MIL-PRF-680	6850-014742313	CLEANING COMPOUND,SOLVENT
MIL-PRF-680	6850-014742316	CLEANING COMPOUND,SOLVENT
MIL-PRF-680	6850-014722721	CLEANING COMPOUND,SOLVENT
MIL-PRF-680	6850-014742317	CLEANING COMPOUND,SOLVENT
MIL-PRF-680	8010-002466112	THINNER,PAINT PRODUCTS
MIL-PRF-680	6850-014722719	CLEANING COMPOUND,SOLVENT
MIL-PRF-680	6850-014742302	CLEANING COMPOUND,SOLVENT
MIL-PRF-680	6850-014742319	CLEANING COMPOUND,SOLVENT
MIL-PRF-680	6850-014742309	CLEANING COMPOUND,SOLVENT
MIL-PRF-680	6850-014722722	CLEANING COMPOUND,SOLVENT
MIL-PRF-680	6850-014742320	CLEANING COMPOUND,SOLVENT
MIL-D-16791	7930-002829700	DETERGENT,GENERAL PURPOSE
MIL-D-16791	7930-005319716	DETERGENT,GENERAL PURPOSE
MIL-D-16791	7930-005319715	DETERGENT,GENERAL PURPOSE
MIL-D-16791	7930-002829699	DETERGENT,GENERAL PURPOSE
MIL-D-16791	7930-009856911	DETERGENT,GENERAL PURPOSE
MIL-D-16791	7930-005319715	DETERGENT,GENERAL PURPOSE

NATIONAL STOCK NUMBER TABLES (continued)

0021 00

Table 21-2. Coating, Aliphatic Polyurethane, Single Component Chemical Agent Resistant, MIL-DTL-53039

COLOR	COLOR NUMBER	NSN	SIZE
Green 383*	34094	8010-01-229-7546	1 Qt Can
Green 383*	34094	8010-01-229-9561	1 Gal Can
Green 383*	34094	8010-01-229-7547	5 Gal Can
Brown 383*	30051	8010-01-229-7543	1 Qt Can
Brown 383*	30051	8010-01-229-7544	1 Gal Can
Brown 383*	30051	8010-01-229-7545	5 Gal Can
Black*	37030	8010-01-229-7540	1 Qt Can
Black*	37030	8010-01-229-7541	1 Gal Can
Black*	37030	8010-01-229-7542	5 Gal Can
Sand	33303	8010-01-234-2934	1 Qt Can
Sand	33303	8010-01-234-2935	1 Gal Can
Sand	33303	8010-01-234-2936	5 Gal Can
Aircraft Green	34031	8010-01-246-0717	1 Qt Can
Aircraft Green	34031	8010-01-246-0718	1 Gal Can
Aircraft Green	34031	8010-01-246-0719	5 Gal Can
Tan 686	33446	8010-01-276-3638	1-Qt Can
Tan 686	33446	8010-01-276-3639	1 Gal Can
Tan 686	33446	8010-01-276-3640	5 Gal

*Not listed on AMDF; must be specially ordered.

NATIONAL STOCK NUMBER TABLES (continued)

0021 00

Table 21-3. Coating, Water Dispersible Aliphatic Polyurethane, Chemical Agent Resistant, MIL-DTL-64159, Type I and Type II

Color	Color Number	NSN	SIZE
TYPE I			
* Green 383	34094	8010-01-492-6638	3 Qt Kit
* Green 383	34094	8010-01-492-6640	15 Gal Kit
* Brown 383	30051	8010-01-492-6641	3 Pt Kit
* Brown 383	30051	8010-01-492-6643	3 Gal Kit
* Brown 383	30051	8010-01-492-6644	15 Gal Kit
**Tan 686A	33446	8010-01-492-6645	3 Pt Kit
**Tan 686A	33446	8010-01-492-6646	3 Qt Kit
**Tan 686A	33446	8010-01-492-6648	3 Gal Kit
**Tan 686A	33446	8010-01-492-6649	15 Gal Kit
*Black	37030	8010-01-492-6650	3 Pt Kit
Aircraft Green	34031	8010-01-492-6655	3 Pt Kit
Aircraft Green	34031	8010-01-492-6656	3 Qt Kit
Aircraft Green	34031	8010-01-492-6657	3 Gal Kit
Aircraft Green	34031	8010-01-492-6658	15 Gal Kit
Gray	36300	8010-01-492-6659	3 Pt Kit
Gray	36300	8010-01-492-6660	3 Qt Kit
Gray	36300	8010-01-492-6661	3 Gal Kit
TYPE II			
* Green 383	34094	8010-01-493-3168	3 Pt Kit
* Green 383	34094	8010-01-493-3170	3 Gal Kit
* Brown 383	30051	8010-01-493-3174	3 Gal Kit
*Black	37030	8010-01-493-3182	3 Pt Kit
*Black	37030	8010-01-493-3183	3 Qt Kit
*Black	37030	8010-01-493-3190	3 Gal Kit
Aircraft Green	34031	8010-01-493-3192	3 Pt Kit
Aircraft Green	34031	8010-01-493-3193	3 Qt Kit
Aircraft Green	34031	8010-01-493-3195	15 Gal Kit
Gray	36300	8010-01-493-3196	3 Pt Kit
Gray	36300	8010-01-493-3197	3 Qt Kit
Gray	36300	8010-01-493-3198	3 Gal Kit
Gray	36300	8010-01-493-3199	15 Gal Kit

* Basic three-color CARC camouflage coatings

** CARC for desert applications

Table 21-4. Coating, Epoxy, High-Solids, MIL-PRF-22750

COLOR	COLOR NUMBER	NSN	SIZE
Gray	16473	8010-01-414-8423	2 Qt Kit
Gray, Lt	36495	8010-01-419-1149	2 Qt Kit
Gray, Lt.	36495	8010-01-419-1144	1 Gal Kit
Gray	36320	8010-01-419-1155	2 Qt Kit
Gray	36375	8010-01-316-3039	2 Gal Kit
Gull Gray	16440	8010-01-419-1163	2 Qt Kit
Gray	36440	8010-01-414-8447	1 Gal Kit
Gray	16081	8010-01-419-1166	2 Gal Kit
Gray	36231	8010-01-419-1150	2 Qt Kit
Orange-Yellow	13538	8010-01-313-7292	2 Qt Kit
White	17925	8010-01-419-1153	2 Qt Kit
White	17925	8010-00-082-2439	2 Gal Kit
White	27875	8010-01-419-1164	1 Gal Kit
White	17925	8010-01-314-4497	10 Gal Kit
Insignia Blue	15044	8010-01-419-1168	2 Qt Kit
Blue	35237	8010-01-419-1145	2 Qt Kit
Blue	35237	8010-01-419-1157	1 Gal Kit
Olive Drab	34088	8010-01-350-2070	2 Gal Kit
Olive Drab	24084	8010-01-350-5240	2 Gal Kit

Table 21-5. Non CARC Coatings, MIL-P-14105

COATING	MILSPEC	COLOR	COLOR NUMBER	NSN	SIZE
Paint, Heat Resistant (For Use on Surfaces Exceeding 400°F (204°C))	MIL-P-14105	Green	34094	8010-01-235-2693	1 Qt Can
	MIL-P-14105	Green	34094	8010-01-235-4164	1 Gal Can
	MIL-P-14105	Brown	30051	8010-01-235-2694	1 Qt Can
	Brown		30051	8010-01-235-2695	1 Gal Can
	MIL-P-14105	Black	37030	8010-01-235-4165	1 Qt Can
	MIL-P-14105	Black	37030	8010-01-235-4166	1 Gal Can
	MIL-P-14105				

Table 21-6. Primers, MIL-DTL-0053022, MIL-DTL-0053030, and MIL-PRF-85582

PRIMER	MILSPEC	TYPE	COLOR	COLOR NUMBE	NSN	SIZE
Primer, Epoxy Coating Corrosion Inhibiting Lead and Chromate Free - For Use on Ferrous and Non-ferrous Surfaces)	MIL-DTL-0053022	I	White	34052	8010-01-193-0516	1 Qt Kit
	MIL-DTL-0053022	I	White	-	8010-01-193-0517	1 Gal Kit
	MIL-DTL-0053022	I	White	-	8010-01-187-9820	5 Gal Kit
Primer Coating, Epoxy, Water Reducible, Lead and Chromate Free - For Use on Ferrous and Non-ferrous Surfaces	MIL-DTL-0053030	-	Reddish Brown	-	8010-01-193-0519	1 Qt Kit
	MIL-DTL-0053030	-	Reddish Brown	-	8010-01-193-0520	1 Gal Kit
	MIL-DTL-0053030	-	Reddish Brown	-	8010-01-193-0521	5 Gal Kit
	MIL-PRF-85582	-	Light Green	-	8010-01-193-0521	1 Qt Kit
	MIL-PRF-85582	-	Light Green	-	8010-01-193-0521	1 Gal Kit
Primer Coating: Epoxy, Waterborne					8010-01-218-0856	
					8010-01-218-7354	

Table 21-7. Primer (Wash) Pretreatment, (Formula No. 117 for metals) (Metric), DOD-P-15328

NSN	SIZE
8030-00-850-7076	1.25 Qt Kit
8030-00-281-2726	1gal kit
8030-00-165-8577	5 Gal Kit

Table 21-8. Acetone, Technical, ASTM D329

NSN	SIZE
6810-00-184-4796	1 Gal

Table 21-9. Thinner, Aircraft Coating, MIL-T-81722

TYPE	NSN	SIZE
TYPE I	8010-00-181-8080	1 Gal
	8010-00-181-8079	5 Gal
TYPE II	8010-01-200-2637	1 Gal
	8010-01-212-1704	5 Gal

Table 21-10. WD CARC Topcoat, Aerosol Spray, Type II

COLOR	COLOR NUMBER	NSN	SIZE
Green	34094	8010-01-546-7712	1 Bx
Tan	33446	8010-01-546-7711	1 Bx
Black	37030	8010-01-546-7713	1 Bx
Brown	30051	8010-01-546-7709	1 Bx
Sand	33303	8010-01-547-1917	1 Bx
Yellow	33538	8010-01-547-1919	1 Bx
Olive drab	34088	8010-01-547-1920	1 Bx
Gray	36231	8010-01-547-1921	1 Bx
Gray	36300	8010-01-547-1922	1 Bx
White	37875	8010-01-547-1923	1 Bx
Aircraft green	34031	8010-01-553-5824	1 Bx
Green	34094	8010-01-546-8093	Box of 12
Brown	30051		(4 of each color)
Black	37030		

Table 21-11. WD CARC Topcoat, Brush-top Applicator, Type II

COLOR	COLOR NUMBER	NSN	SIZE
Green	34094	8010-01-546-7585	1 Bx
Tan	33446	8010-01-546-7587	1 Bx
Black	37030	8010-01-546-7588	1 Bx
Brown	30051	8010-01-546-7589	1 Bx
Aircraft red	31136	8010-01-546-7591	1 Bx
Aircraft insignia blue	35044	8010-01-546-7592	1 Bx
Sand	33303	8010-01-547-1876	1 Bx
Yellow	33538	8010-01-547-1878	1 Bx
Olive drab	34088	8010-01-547-1880	1 Bx
Gray	36231	8010-01-547-1882	1 Bx
Gray	36300	8010-01-547-1884	1 Bx
White	37875	8010-01-547-1888	1 Bx
Green	34094		Box of 12
Brown	30051	8010-01-546-7590	(4 of each color)
Black	37030		

Table 21-12. WD CARC Topcoat, Roller-top Applicator, Type II

COLOR	COLOR NUMBER	NSN	SIZE
Green	34094	8010-01-546-7593	1 Bx
Tan	33446	8010-01-546-7594	1 Bx
Black	37030	8010-01-546-7596	1 Bx
Brown	30051	8010-01-546-7595	1 Bx
Aircraft red	31136	8010-01-546-7598	1 Bx
Aircraft insignia blue	35044	8010-01-546-7599	1 Bx
Aircraft white	37875	8010-01-546-7699	1 Bx
Aircraft yellow	33538	8010-01-546-7700	1 Bx
Sand	33303	8010-01-547-1906	1 Bx
Olive drab	34088	8010-01-547-1908	1 Bx
Gray	36231	8010-01-547-1910	1 Bx
Gray	36300	8010-01-547-1913	1 Bx
Aircraft green	34031	8010-01-553-5822	1 Bx
Green	34094		Box of 12
Brown	30051	8010-01-546-7597	(4 of each color)
Black	37030		

END OF WORK PACKAGE

GLOSSARY

The following terms are defined as they are used with respect to painting and related operations.

Abrasive resistance - This property is comparable to toughness rather than hardness. It is that property exhibited by surface of a paint, enamel, or varnish which will resist being worn away by rubbing or friction.

Adhesion - As used in reference to paint films, adhesion is tendency of film, when dry, to bond to surface upon which it has been applied.

Alligatoring - Rupturing of top paint coat, which causes surface to break up into irregular areas separated by wide cracks in an "alligator hide" fashion.

Atomization - A paint and air mixture, whose round or oval pattern is generated by mixing of paint/material, and compressed air at air cap of a spray gun.

Binder - The nonvolatile portion of a paint vehicle. Binders may be drying oils, resins, or a number of other substances such as casein, chlorinated rubber, nitrocellulose, or ethyl cellulose.

Blast cleaning - Blast cleaning to "white metal" is defined as blast cleaning which removes completely all visible mill scale, rust, paint, foreign matter, and pitted areas from surface of metal. The end result must be a light-gray steel surface of uniform appearance.

Bleeding - When color of a pigment in a previous coat comes through topcoat. This usually occurs when a previously applied pigment is soluble in medium of newly applied topcoat. Asphalt and colored resins may also bleed.

Blistering - A condition in which paint coat is detached and raised from surface upon which it is applied as a result of gases or liquids, usually water, forming beneath coating.

Blushing - The precipitation of ingredients of a paint film when it dries, which may be caused by condensation of moisture on film or by improper composition of paint.

Body - A paint is said to have "body" or to be "bodied" when it is thickened above its normal condition. Thus "body" of a paint is its relative thickness. The degree of "body" is in proportion to a paint's viscosity.

Boxing - The process of mixing paint by pouring it back and forth from one container to another.

Brightness - The brightness of a paint film is measured by percentage of incident light reflected from film.

Brushing property - The quality a paint displays when it is applied to a surface, as affected by its viscosity, mobility, consistency, composition, etc.

GLOSSARY (continued)

CARC - Chemical Agent Resistant Coatings; a system of primers and topcoats that are required on all combat, combat support, and combat service support equipment. CARC is used to provide camouflage protection and/or chemical agent resistance to liquid chemical agents. Since CARC does not absorb chemical agents it does not create long term contact hazards.

Catalyst - A substance used in manufacture of paint that causes a chemical and/or physical reaction to take place.

Chalking - When loose powder, which can be removed by gentle rubbing, appears on paint film or just beneath surface. A good quality paint applied correctly should chalk very slowly. Chalking should be a gradual process over a period of years, so that when repainting becomes necessary, the surface is in good condition to receive the new coat, with little, if any, preparatory work required.

Checking - A paint film condition with slight breaks in film surface, causing undercoats to be visible.

Coat-Coating -A protective film of paint, varnish, primer, lacquer, etc.

Confined Space - Any area where dilution ventilation cannot take place, or where air flow is obstructed.

Cracking - Breaks in a paint film which extend through film to underlying material.

Crawling/Creeping - The collection of paint into little drops or islands on applied surface.

Drying oil - An oil which, when exposed in a thin film to air, possesses to a marked degree property of readily absorbing oxygen and changes to a relatively hard, tough, and elastic substance.

Dulling - The loss of gloss which develops in a varnish film after drying.

Enamel - A paint which has ability to form an especially smooth film. An enamel always contains pigment and has moderate hiding power and color. Some enamels dry to a flat or eggshell finish instead of a gloss finish. An enamel is a finish that comprises a dispersion of pigments in a varnish or resin vehicle or is a combination of both. This includes all CARC coatings. Enamels dry by a process of oxidation and/or polymerization.

Feathering - The procedure of thinning a coating between a bare and a painted surface by sanding to a fine edge. It is used when preparing touchup spots for painting and where an invisible lap is required.

Finish system - A particular combination of primers, topcoats, and pretreatment materials that are used on a specific type of surface in order to obtain a desired result (i.e. camouflage, chemical agent resistance, etc.) Also referred to as a paint system.

Filler - A special paint used for filling pores or other breaks in a surface to make it smooth for further painting. When applied and exposed to air, a filler should dry to a relatively hard, permanent solid, capable of supporting subsequent coats.

GLOSSARY (continued)

Flaking - When small pieces of paint coat fall away.

Gloss - The degree of mirror-like reflection of a painted surface.

Hiding power - The ability of a paint or paint material to cover up a surface so that surface cannot be seen.

Hydrocarbons - An organic compound, such as acetylene or benzene that contains only carbon and hydrogen, and occurs in petroleum, natural gas, coal, and bitumens.

Induction - A period of time required for recently mixed materials to begin to react prior to use.

Leveling - The ability of a paint to flow, leaving a smooth film when brushed onto a surface.

Mildew - A fungus frequently noted on surfaces exposed to damp, warm climates. This is usually found on surfaces covered with paint of a soft nature. Such paints act like flypaper, and afford lodging for windblown matter from decayed and dried vegetation. Sometimes oil with which paint is made or mixed from is infected and offers a breeding place for mildew spores.

Opacity - The degree of obstruction of a coating to the transmission of visible light.

Oxidation - In coatings, curing reaction which requires oxygen from air to form film.

Paint - Paint is composed of a pigment and a vehicle. The pigment, or solid component, is dispersed in paint, provides color to paint, and enables it to form a film on painted surface. The vehicle is liquid portion of a paint, which includes components that serve as binders, as well as volatile components known as thinners. The binder portion of vehicle, like pigment, is film forming. After evaporation of volatile content, drying is by oxidation.

Paint system - The protective paint barrier that covers a painted object, and may consist of a pretreatment coat, primer coats, intermediate coats, and/or finish or top coats. Also referred to as a finish system.

Peeling - A more aggravated form of scaling, usually due to presence of moisture when paint was applied or to faulty application of priming coat.

Pigment - The fine, solid particles used in preparation of paint, substantially insoluble in vehicle. Pigments provide coloration, corrosion resistance, strength, hardness, increased durability, and control of gloss.

Polymerization - The reaction, usually at elevated temperatures, in which two or more components of substance combine to form a more complex molecular structure, which has property of curing or solidifying with or without absorption of oxygen.

Pretreatment coat - The wash primer or preprimer paint film that is applied under regular primer paint coat, and is used for better bonding and corrosion control.

Primer - A paint which is intended for use as initial covering for a surface and is usually followed by other coats, often of a different type of paint. Primers are also called undercoats, and usually contain corrosion resistant properties.

GLOSSARY (continued)

Respiratory protection, approved - Approved respiratory protection equipment is that equipment tested and listed as satisfactory according to standards established by a competent authority, such as the National Institute for Occupational Safety and Health (NIOSH), or the Mine Safety and Health Administration (MSHA), to provide respiratory protection against hazard for which it is designed. The specific approval authority may be specified by law for particular hazards.

Runs - Sags - Irregularities of paint film due to uneven flow of paint.

Scaling - Flaking of paint film in an aggravated form in which paint coating falls off in large sections.

Solvent - A volatile thinner, particularly for varnishes and lacquers.

Spotting - The appearance of discolored spots on a painted or varnished surface.

Spray coat - A spray coat consists of one or more coats, depending on paint, and should be considered as that amount of paint applied at one time, just short of sagging, running, or wrinkling.

Stripper - Any solution used for paint removal.

Stripping - The process of removing paint from a painted surface by means of a stripper.

Sweating - A term used to describe reappearance of luster on a varnished surface which has been rubbed to a dull finish.

Thinner - Thinners make a paint workable, adjusting consistency for easy application, and producing a uniform film that will penetrate and adhere to surface. The thinner, being volatile, evaporates and does not provide part of dried surface film.

Toxic - A paint or other product that has poisonous qualities. While some paints and related materials have toxic qualities with respect to using personnel, products which are named "toxic paints" are developed for their poisonous qualities against fungi, teredo, barnacles, etc.

Vehicle - The liquid portion of a paint which carries pigments. Anything that is dissolved in liquid portion of a paint becomes a part of vehicle.

Washing - Paint films sometimes allow pigment to "wash" out under action of elements. When rubbed, a wet, soapy, emulsion will be formed. This is termed "washing".

Wrinkling - Sometimes referred to as "crinkling", "puckering", or "crimping", this describes a condition in which paint film gathers in wrinkles. It frequently occurs when paint or varnish is applied at low temperatures.

INDEX

<u>Subject</u> <u>No.</u>	<u>WP Sequence</u>
B	
Brush or Roller Application.....	WP 0014 00
C	
Camouflaging Pattern Painting.....	WP 0011 00
Cleaners.....	WP 0005 00
Cleaning and Treatment of Surfaces.....	WP 0008 00
F	
Fillers.....	WP 0003 00
G	
General Information.....	WP 0001 00
I	
Inspection Procedures.....	WP 0012 00
L	
Lettering and Sign Painting.....	WP 0016 00
N	
National Stock Number Tables.....	WP 0021 00
P	
Painting.....	WP 0009 00
Paint Failures.....	WP 0015 00

INDEX (continued)

P (continued)

Pouncing..... WP 0019 00
Pressure Sensitive Adhesive Vinyl Markers (Decals)..... WP 0018 00
Primers..... WP 0004 00

R

References..... WP 0020 00

S

Safety Summary..... WP 0002 00
Specific Finish Systems..... WP 0010 00
Spot Painting..... WP 0007 00
Spray Guns and Pressure Guns..... WP 0013 00
Stencil and Paint Marking..... WP 0017 00

T

Thinners..... WP 0006 00

By Order of the Secretary of the Army:



GEORGE W. CASEY, JR.
General, United States Army
Chief of Staff

Official:



JOYCE E. MORROW
Administrative Assistant to the
Secretary of the Army
0804302

DISTRIBUTION: To be distributed in accordance with the Initial Distribution Number (IDN) 340868,
requirements for TM 43-0139

RECOMMENDED CHANGES TO PUBLICATIONS AND BLANK FORMS For use of this form, see AR 25-30; the proponent agency is OAASA						Use Part II (reverse) for Repair Parts and Special Tools Lists (RPSTL) and Supply Catalogs/Supply Manuals (SC/SM)	DATE (Date You Will Fill Out This Form)
TO: (Forward to proponent of publication or form) (Include Zip Code)						FROM: (Activity and location) (Include Zip Code) (Your Mailing Address)	
PART I - ALL PUBLICATIONS (EXCEPT RPSTL AND SC/SM) AND BLANK FORMS							
PUBLICATION FORM NUMBER TM 43-0139						DATE 30 June 2008	TITLE Painting Instructions for Army Materiel
ITEM	PAGE NO.	PARA-GRAPH	LINE	FIGURE NO.	TABLE	RECOMMENDED CHANGES AND REASON	
	0004 00-3					Callouts on art are numbered incorrectly. Callouts 3, 4, and 5 should be 6, 7, and 8.	
							
<i>* Reference to line numbers within the paragraph or sub paragraph.</i>							
TYPED NAME, GRADE OR TITLE John Doe SSG				TELEPHONE EXCHANGE/AUTOVON, PLUS EXTENSION xxx-xxxx		SIGNATURE 	

TO: (Forward direct to addressee listed in publication)	FROM: (Activity and location)(Include Zip Code) (Your Mailing Address)	DATE (Date You Will Fill Out This Form)
--	--	--

PART II - REPAIR PARTS AND SPECIAL TOOLS LISTS AND SUPPLY CATALOGS/SUPPLY MANUALS

PUBLICATION NUMBER TM 43-0139	DATE 30 June 2008	TITLE Painting Instructions for Army Materiel
---	---------------------------------	---

PAGE NO.	COLM NO.	LINE NO.	NATIONAL STOCK NUMBER	REFERENCE NO.	FIGURE NO.	ITEM NO.	TOTAL NO. OF MAJOR ITEMS SUPPORTED	RECOMMENDED ACTION
260			4730-00-273-6772		134		4	Change from Hex to Socket Plug.
260-1			4730-00-273-6772				4	Change Part Number to 12301694.

PART III - REMARKS (Any general remarks or recommendations, or suggestions for improvement of publications and blank forms. Additional blank sheets may be use dif more space is needed.)

SAMPLE

TYPED NAME, GRADE OR TITLE John Doe SSG	TELEPHONE EXCHANGE/AUTOVON, PLUS EXTENSION xxx-xxxx	SIGNATURE <i>John Doe</i>
---	---	---

RECOMMENDED CHANGES TO PUBLICATIONS AND BLANK FORMS For use of this form, see AR 25-30; the proponent agency is OAASA						Use Part II (reverse) for Repair Parts and Special Tools Lists (RPSTL) and Supply Catalogs/Supply Manuals (SC/SM)	DATE
TO: (Forward to proponent of publication or form)(Include Zip Code)						FROM: (Activity and location)(Include Zip Code)	
PART I - ALL PUBLICATIONS (EXCEPT RPSTL AND SC/SM) AND BLANK FORMS							
PUBLICATION FORM NUMBER TM 43-0139						DATE 30 June 2008	TITLE Painting Instructions for Army Materiel
ITEM	PAGE NO.	PARA-GRAPH	LINE	FIGURE NO.	TABLE	RECOMMENDED CHANGES AND REASON	
* Reference to line numbers within the paragraph or sub paragraph.							
TYPED NAME, GRADE OR TITLE					TELEPHONE EXCHANGE/AUTOVON, PLUS EXTENSION		SIGNATURE

TO: <i>(Forward direct to addressee listed in publication)</i>	FROM: <i>(Activity and location)(Include Zip Code)</i>	DATE
---	---	------

PART II - REPAIR PARTS AND SPECIAL TOOLS LISTS AND SUPPLY CATALOGS/SUPPLY MANUALS

PUBLICATION NUMBER TM 43-0139	DATE 30 June 2008	TITLE Painting Instructions for Army Materiel
----------------------------------	----------------------	--

PAGE NO.	COLM NO.	LINE NO.	NATIONAL STOCK NUMBER	REFERENCE NO.	FIGURE NO.	ITEM NO.	TOTAL NO. OF MAJOR ITEMS SUPPORTED	RECOMMENDED ACTION

PART III - REMARKS *(Any general remarks or recommendations, or suggestions for improvement of publications and blank forms. Additional blank sheets may be use dif more space is needed.)*

TYPED NAME, GRADE OR TITLE	TELEPHONE EXCHANGE/AUTOVON, PLUS EXTENSION	SIGNATURE
----------------------------	--	-----------

RECOMMENDED CHANGES TO PUBLICATIONS AND BLANK FORMS For use of this form, see AR 25-30; the proponent agency is OAASA						Use Part II (reverse) for Repair Parts and Special Tools Lists (RPSTL) and Supply Catalogs/Supply Manuals (SC/SM)	DATE
TO: (Forward to proponent of publication or form)(Include Zip Code)						FROM: (Activity and location)(Include Zip Code)	
PART I - ALL PUBLICATIONS (EXCEPT RPSTL AND SC/SM) AND BLANK FORMS							
PUBLICATION FORM NUMBER TM 43-0139						DATE 30June2008	TITLE Painting Instructions for Army Materiel
ITEM	PAGE NO.	PARA-GRAPH	LINE	FIGURE NO.	TABLE	RECOMMENDED CHANGES AND REASON	
<i>* Reference to line numbers within the paragraph or sub paragraph.</i>							
TYPED NAME, GRADE OR TITLE					TELEPHONE EXCHANGE/AUTOVON, PLUS EXTENSION		SIGNATURE

TO: <i>(Forward direct to addressee listed in publication)</i>	FROM: <i>(Activity and location)(Include Zip Code)</i>	DATE
---	---	------

PART II - REPAIR PARTS AND SPECIAL TOOLS LISTS AND SUPPLY CATALOGS/SUPPLY MANUALS

PUBLICATION NUMBER TM 43-0139	DATE 30 June 2008	TITLE Painting Instructions for Army Materiel
----------------------------------	----------------------	--

PAGE NO.	COLM NO.	LINE NO.	NATIONAL STOCK NUMBER	REFERENCE NO.	FIGURE NO.	ITEM NO.	TOTAL NO. OF MAJOR ITEMS SUPPORTED	RECOMMENDED ACTION

PART III - REMARKS *(Any general remarks or recommendations, or suggestions for improvement of publications and blank forms. Additional blank sheets may be use dif more space is needed.)*

TYPED NAME, GRADE OR TITLE	TELEPHONE EXCHANGE/AUTOVON, PLUS EXTENSION	SIGNATURE
----------------------------	--	-----------

RECOMMENDED CHANGES TO PUBLICATIONS AND BLANK FORMS For use of this form, see AR 25-30; the proponent agency is OAASA						Use Part II (reverse) for Repair Parts and Special Tools Lists (RPSTL) and Supply Catalogs/Supply Manuals (SC/SM)	DATE
TO: (Forward to proponent of publication or form)(Include Zip Code)						FROM: (Activity and location)(Include Zip Code)	
PART I - ALL PUBLICATIONS (EXCEPT RPSTL AND SC/SM) AND BLANK FORMS							
PUBLICATION FORM NUMBER TM 43-0139						DATE 30 June 2008	TITLE Painting Instructions for Army Materiel
ITEM	PAGE NO.	PARA-GRAPH	LINE	FIGURE NO.	TABLE	RECOMMENDED CHANGES AND REASON	
* Reference to line numbers within the paragraph or sub paragraph.							
TYPED NAME, GRADE OR TITLE					TELEPHONE EXCHANGE/AUTOVON, PLUS EXTENSION		SIGNATURE

TO: <i>(Forward direct to addressee listed in publication)</i>	FROM: <i>(Activity and location)(Include Zip Code)</i>	DATE
---	---	------

PART II - REPAIR PARTS AND SPECIAL TOOLS LISTS AND SUPPLY CATALOGS/SUPPLY MANUALS

PUBLICATION NUMBER TM 43-0139	DATE 30 June 2008	TITLE Painting Instructions for Army Materiel
----------------------------------	----------------------	--

PAGE NO.	COLM NO.	LINE NO.	NATIONAL STOCK NUMBER	REFERENCE NO.	FIGURE NO.	ITEM NO.	TOTAL NO. OF MAJOR ITEMS SUPPORTED	RECOMMENDED ACTION

PART III - REMARKS *(Any general remarks or recommendations, or suggestions for improvement of publications and blank forms. Additional blank sheets may be use dif more space is needed.)*

TYPED NAME, GRADE OR TITLE	TELEPHONE EXCHANGE/AUTOVON, PLUS EXTENSION	SIGNATURE
----------------------------	--	-----------

THE METRIC SYSTEM AND EQUIVALENTS

LINEAR MEASURE

1 Centimeter = 10 Millimeters = 0.01 Meters = 0.3937 Inch
 1 Meter = 100 Centimeters = 1000 Millimeters = 39.37 Inches
 1 Kilometer = 1000 Meters = 0.621 Mile

WEIGHTS

1 Gram = 0.001 Kilogram = 1000 Milligrams = 0.035 Ounce
 1 Kilogram = 1000 Grams = 2.2 Lb
 1 Metric Ton = 1000 Kilograms = 1 Megagram = 1.1 Short Tons

LIQUID MEASURE

1 Milliliter = 0.001 Liter = 0.0338 Fluid Ounce
 1 Liter = 1000 Milliliters = 33.82 Fluid Ounces

SQUARE MEASURE

1 Sq. Centimeter = 100 Sq. Millimeters = 0.155 Sq. Inch
 1 Sq. Meter = 10,000 Sq. Centimeters = 10.76 Sq. Feet
 1 Sq. Kilometer = 1,000,000 Sq. Meters = 0.386 Sq. Mile

CUBIC MEASURE

1 Cu. Centimeter = 1000 Cu. Millimeters = 0.06 Cu. Inch
 1 Cu. Meter = 1,000,000 Cu. Centimeters = 35.31 Cu. Feet

TEMPERATURE

$5/9 (^{\circ}\text{F} - 32) = ^{\circ}\text{C}$
 212° Fahrenheit is equivalent to 100° Celsius
 90° Fahrenheit is equivalent to 32.2° Celsius
 32° Fahrenheit is equivalent to 0° Celsius
 $9/5 ^{\circ}\text{C} + 32 = ^{\circ}\text{F}$

APPROXIMATE CONVERSION FACTORS

TO CHANGE	TO	MULTIPLY BY
Inches	Centimeters	2.540
Feet	Meters	0.305
Yards	Meters	0.914
Miles	Kilometers	1.609
Square Inches	Square Centimeters	6.451
Square Feet	Square Meters	0.093
Square Yards	Square Meters	0.836
Square Miles	Square Kilometers	2.590
Acres	Square Hectometers	0.405
Cubic Feet	Cubic Meters	0.028
Cubic Yards	Cubic Meters	0.765
Fluid Ounces	Milliliters	29.573
Pints	Liters	0.473
Quarts	Liters	0.946
Gallons	Liters	3.785
Ounces	Grams	28.349
Pounds	Kilograms	0.454
Short Tons	Metric Tons	0.907
Pound-Feet	Newton-Meters	1.356
Pounds per Square Inch	Kilopascals	6.895
Miles per Gallon	Kilometers per Liter	0.425
Miles per Hour	Kilometers per Hour	1.609

TO CHANGE	TO	MULTIPLY BY
Centimeters	Inches	0.394
Meters	Feet	3.280
Meters	Yards	1.094
Kilometers	Miles	0.621
Square Centimeters	Square Inches	0.155
Square Meters	Square Feet	10.764
Square Kilometers	Square Miles	0.386
Square Hectometers	Acres	2.471
Cubic Meters	Cubic Feet	35.315
Cubic Meters	Cubic Yards	1.308
Milliliters	Fluid Ounces	0.034
Liters	Pints	2.113
Liters	Quarts	1.057
Liters	Gallons	0.264
Grams	Ounces	0.035
Kilograms	Pounds	2.205
Metric Tons	Short Tons	1.102
Newton-Meters	Pound-Feet	0.738
Kilopascals	Pounds per Square Inch	0.145
Kilometers per Liter	Miles per Gallon	2.354
Kilometers per Hour	Miles per Hour	0.621



